

Sanibel - Captiva

Islander

since 1961

vol. 18, no. 29

tuesday, july 18, 1978

one section

ten cents

25

flood elevation levels to be reviewed today

by gwen stevenson

At last Tuesday's meeting, the City Council adopted the minimum height elevations required by the Flood Insurance Study that was recently done throughout the county. The minimum elevations for Sanibel range from 10 to 12 feet in the interior and 13.5 feet within 500 feet of the Gulf or Bay waters.

The flood elevations determinations are now undergoing a 90-day appeal process before they become law. That period ends Oct. 14, 1978. During the next three months, any owner or lessee of real property in on Sanibel who believes that his property rights will be adversely affected by the proposed base flood elevation determinations may appeal to Sanibel Mayor Zee Butler or a designated agency. The sole basis for an appeal, however, is the possession of knowledge indicating that the proposed base flood elevations are scientifically or technically incorrect.

The Council's action took some Islanders by surprise, although the adopting of the flood elevations had been advertised for two weeks prior to the council meeting, the flood elevation

cont. on page 3

photo by Tim Elliott

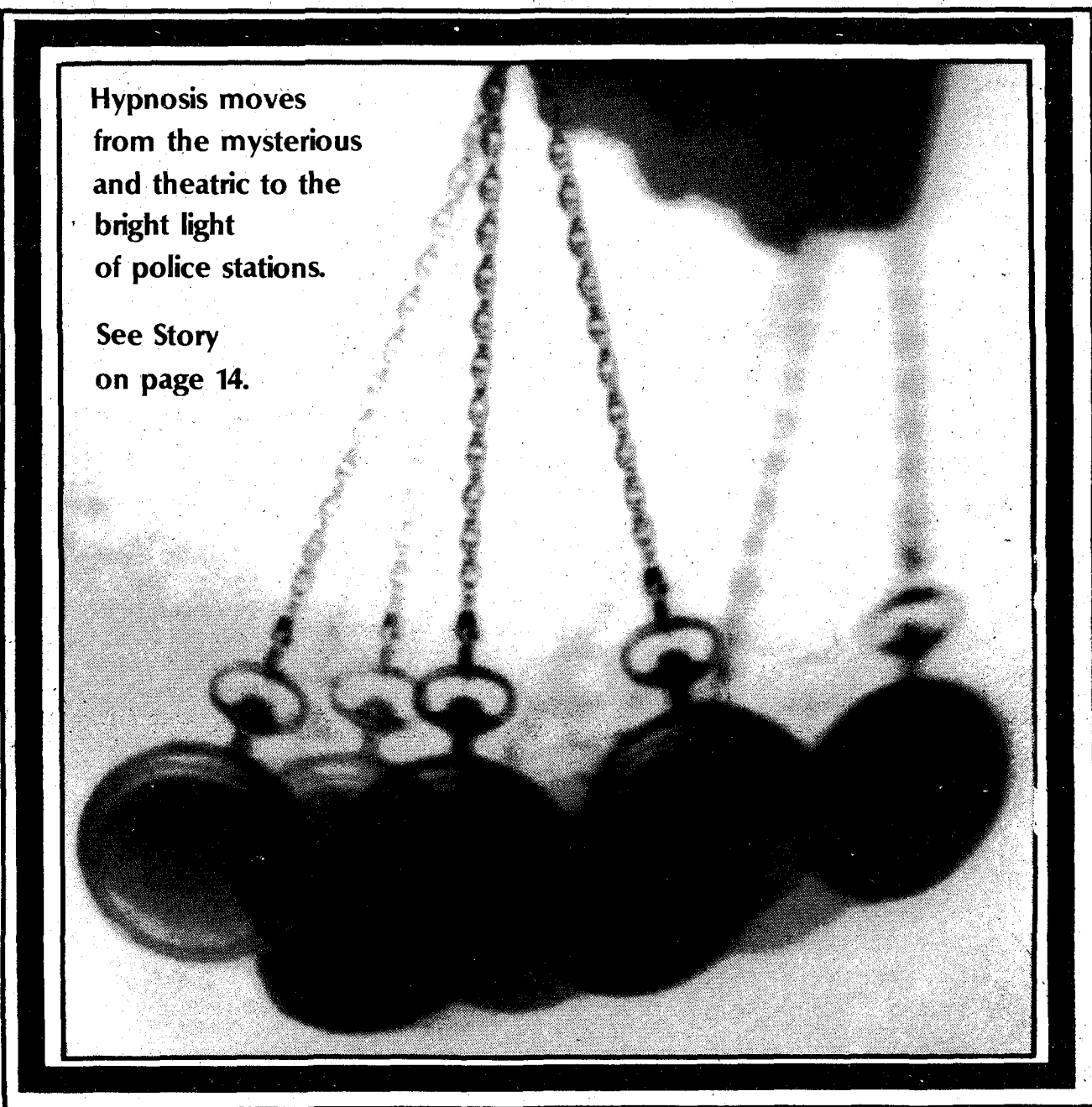

Hypnosis moves from the mysterious and theatric to the bright light of police stations.

See Story on page 14.

planning commission requests council to reconsider donax intersection plans

by betsey mallett

The Planning Commission voted unanimously yesterday, Monday, July 24, to recommend to the City Council that they reconsider the proposal for Donax Street alignment.

A motion by Commissioner Ray Fenton, proposed that the council get engineering work done that would provide a minimum amount of reconstruction on Periwinkle Way; that reconstruction take place within the existing right-of way; that they include an additional left-hand turn on Periwinkle Way west-bound; that there be no right-hand deceleration lane for east-bound Periwinkle traffic; that the city continue to use traffic aides during peak hours and that any money saved by redoing the intersection plans be funneled into Gulf Drive connectors.

The controversial 90 degree angle proposed in Alternative One will not, according to Rocky Van Gilder, an engineer with Harold, Needles, Tammen and Bergdorf increase the capacity of the traffic through the intersection, although it would, he conceded, improve safety but added

that that could be improved in other ways without spending as much money.

In other action, the Commission approved a specific amendment to permit the construction of a "more

than 50 percent of existing building" addition requested by the Sanibel Community Association.

----granted a one-half specific amendment to William and Vivian Snyder to allow a 35-foot encroachment on their Tradewinds property to make room for the construction of a single-family residence. A similar amendment was granted to Donald Anderson last year for the adjoining property.

--approved a development permit for a 14-unit condominium and pool by David Squires.

---approved a request for a specific amendment by the Christian Science group to permit construction of a church in the Palm Lake subdivision, requested by Shirley Shakespeare who was representing the Group. The property was deeded to the Church in 1962 and in the subdivision in subsequent years have been aware that the Church holds that property and would probably build at a future date.

--approved 14 single-family users for water under ordinance 770 77-47.

city gets o.k. for bike path route

by gwen stevenson

Mayor Zee Butler visited Washington, D.C. last week to request the cooperation of the United States Fish and Wildlife service in placing a proposed bike path along Sanibel-Captiva Road on the federally-owned property of the J.N. (Ding) Darling Refuge.

As a result of her trip, the city of Sanibel has been granted permission to place the bike path north of and adjacent to the vegetation line on the Sanibel-Captiva Road.

In reversing a previous decision by the regional Atlanta office who had turned down the proposal, Lynn Greenwald, director of the U.S. Fish and Wildlife Service agreed with the

mayor that cooperation between the Wildlife service and the city was in everyone's best interests. Greenwald also agreed to endorse a request by Sanibel for a six-month extension on the city's \$50,000 grant from the department of Natural Resources to help fund the bike path.

Mayor Butler said she was very grateful to be able to see the person who makes the decisions and credited the favorable decision in part to help she had from Congressman "Skip" Bifulco's office, who sent administrative assistant Dick Nelson to the meeting as well as John Clark, Associate of the Conservation Foundation in Washington.

south florida water management district well permit policy

The Board for the South Florida Water Management District (SF-WMD), at its regular July 3 meeting, directed the District staff to design a rule that would bring nearly all water users in the District's jurisdiction under their permit requirements. Currently, only wells drawing more than 100,000 gallons of water per day are required to obtain a consumptive

use permit from the District.

"We have no desire to burden the small water user with time consuming and expensive engineering forms," noted Jack Maloy, District Executive Director. "To protect the resource, however, as well as land owners, we may have to take this route." The route Maloy is considering recommending would require that a general

permit be issued for these new, relatively small users, except in an area where long-term water shortages have been identified. The only two areas in the District thus far where that has happened are Sanibel and Staurt in Marin County. In these areas, according to Maloy, full permit applications and reviews would be required for any use over 10,000 gallons per day.

Maloy explained that in 1974, when the District began implementing the regulatory or permitting provisions of the Water Resources Act, the Board decided to exempt all water users under 100,000 gallons per day from the permit process. It was believed that any use under this amount did not substantially effect the resource.

In cases of water shortage, however, Maloy feels almost every user affects the resource and must be calculated into the formula for providing water - even in a limited amount - to the people of the area.

"We have also discovered that by exempting a certain group of people from the process, we have made it difficult for them to obtain any water rights at all," Maloy said. According to District Dick Rogers that is the primary purpose of the plan.

"It is also one way to help solve the problem of people going out and doing things on their own. 'Frankly,' he added, 'we're not as nervous about Sanibel as the rest of the District. The Board has asked us to prepare a statement on the District-wide impact of the program,' he said, 'but I don't think there will be any real impact on the water. We will probably be holding public hearings throughout the District, including Sanibel, before we make a final recommendation to the Board,'"

Before the Water Resources Act was passed, according to Maloy, Florida land owners held common law rights to water that lay beneath their property. Legislation in 1972 changed that and made water rights dependent on receiving a permit for the use of that water. The system is adequate for users who require more than 100,000 gallons of water per day, but smaller users now have no way to obtain a legal right to use water.

This becomes particularly critical if a conflict of uses arises or if there is a water shortage emergency declared and water allocations are made, since such allocations are only made to permit holders.

Maloy pointed out that domestic, household use of water and water used solely for individual lawn irrigation and for firefighting purposes and will continue to be exempt from the District's permit requirements.

Under a general permit, a simple notice of intent to use water would require to be filed by the water user. This would not involve any engineering knowledge, but be a minimum informational document to establish the individual as a legal user of water. All current water users would have two years from the implementation of such a rule to actually file this notice.

The SFWMD Board will discuss formation of such a rule again at its August 10 workshop and regulatory meetings.

public hearing on Dunes well request tomorrow

The South Florida Water Management District (SFWMD) will hold a public hearing tomorrow, Wednesday, July 26 at 9:30 a.m., on a request by John Kontinos to re-open a well that taps into the Suwanee Aquifer. The well is located on the Dunes property and according to the application, the water will be used to irrigate the Dunes golf course.

Kontinos is requesting permission to withdraw 306,000 gallons per day from the well. The staff from the District has prepared a preliminary report recommending that the withdrawal permit be approved.

Larry Snell told the ISLANDER last Friday that the Island Water Association (IWA) is not going to recommend that the permit be denied but they are going to ask that Kontinos be required to do the same hydrological testing that the IWA has been required to do to determine the impact on the Aquifer and to see what effect the well will have on the IWA itself and whether the withdrawals will shorten the life span of the Lower Hawthorne.

"Even though the well is supposed to be drilled into the Suwanee Aquifer," Snell said, "it is so old and rusty that

the water they get is not confined just to that Aquifer. We also feel that they have asked for substantially more water than they need to irrigate the 53-acre golf course.

Consulting hydrologist, Carl Nuzman, chief hydrologist with Layne, Western Co., in Mission, Kansas, doesn't feel that the importance of the permit rests with the amount of the water that Kontinos is requesting to withdraw, but that, given the Sanibel situation, there should be alternate sources available and they should be utilized.

"My concern is where this water is coming from and whether or not alternate sources could be utilized to accomplish the same goal," Nuzman said in a telephone interview Friday. He also added that he had just returned from a jury case and was in the process of doing a total review of the "Sanibel situation." Nuzman has been retained by the City of Sanibel to review the Island city's water situation and to coordinate his information with the IWA.

The hearing tomorrow will be held at the Community Association Building on Periwinkle Way.

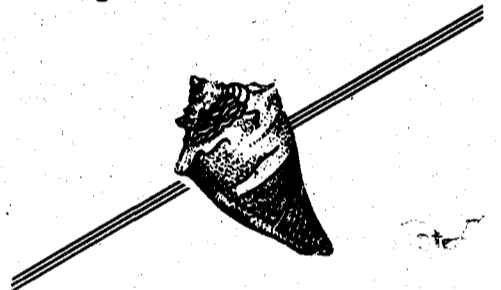

IDLE HOURS

31 Periwinkle Place
Sanibel
Phone 472-1039

MACRAME
Cords, Beads, Books and Hardware

- * SANIBEL NEEDLEPOINT KITS by B.J. PUFF
- * WEAVING YARNS AND CANVASES
- * CREWEL AND EMBROIDERY
- * SPINNERIN PATTERNS AND YARNS
- * NORWEGIAN WOOL FOR SWEATERS
- * RYA RUGS • X-ACTO HOUSE OF MINIATURES

SANIBEL STANDARD

472-2125

MON.-FRI. 7 to 6
SAT. & SUN. 8 to 6

JIM ANHOLT, OWNER

Miki's House

SANIBEL ISLAND
DESIGNER'S GUILD INTL

Sign up for classes now in: Jewelry, large and small shell flowers, fabric painting & trapunto. Also we have the latest in stickpins, chains and findings for your shell work.

1989 Periwinkle Way at Tahitian Garden

LAUHAHA MATS
4'x8' \$6⁰⁰ each

Wicked Woman 936-8916

Wicker Woman

We love browsers.

3319 Cleveland Ave., Fort Myers

SANTIVA MINI MART

Grocery - Dairy - Frozen Foods
Meats - Cold Beer & Wine
Fishing Tackle
Post Cards - Magazines
Hats
Health & Beauty Aids

NORTH END OF SANIBEL
AT BLIND PASS BRIDGE

FOR QUICK CONVENIENT SHOPPING
OPEN SEVEN DAYS A WEEK TO SERVE YOU
7 A.M. TO 9 P.M.

council passes moratorium on multi-family

The Sanibel city council passed a moratorium granting a temporary halt to the issuance of development or building permits until January 1, 1979 or until the council makes a decision on a proposed rate of growth ordinance submitted by the Committee of the Islands (COTI). COTI has obtained the

necessary number of signatures required by the city charter to submit the ordinance to the council.

The moratorium, effective immediately, does not apply to duplexes or single-family homes or to requests for development and building permits already submitted to the city.

Porter Goss, Duane White and Charles LeBuff voted for the moratorium while Zee Butler and Francis Bailey voted against.

City Manager Bill Nungester told the council that, since the ordinance had its first reading on June 6, city hall had approved 143 dwelling units.

Councilman Goss pointed out that this type of "panic" situation was what he wished to avoid with the moratorium. Sanibel realtor Stan Johnson vehemently disagreed, saying that it was the threat of the moratorium that had sparked the unusual number of permits requests.

A group of Sanibel businessmen feel that the moratorium ordinance is invalid and are investigating the possibility of challenging the ordinance in court, according to David G. Thompson, spokesman for the group. A decision on that action is expected later this week.

In another action that would constrain condominium building on the Island, the Council, by the same voting margin of 3-2, held a first reading of an ordinance that would require all multi-

family housing to be approved by the voters.

Councilman Goss, who made the motion, was emphatic in his statement that this would not alter any of the provision of the comprehensive land use plan. "It is just another hoop for the developer to go through," he said, "in addition to the plan."

Upon being assured by consulting attorney Fred Bosselman of Ross, Hardies et al that it "would have no adverse impact on the plan and that it was compatible with the COTI proposal," Duane White reversed his earlier position and voted in favor of it.

Stan Johnson criticized the ordinance on the grounds that "apartments are a way of life for some people." You are removing that option,"

Stan Johnson criticized the ordinance on the grounds that "apartments are a way of life for some people: You are removing that option," Johnson told the council.

The ordinance must pass a second reading before becoming law. The council agreed with Goss' suggestion that the date be set after coordinating it with the COTI rate of growth proposal.

flood elevation

from page one

standards were not explicitly designated as an agenda item for last Tuesday's meeting.

Adopting the minimum height of 10 feet means that future building on Sanibel will be piling homes. Estimates of the increased price of piling house range from 10 to 30 percent over a cinder block house.

Stan Johnson, president of Priscilla Murphy Real Estate said that "While people have been expecting the increase intellectually, they still are not aware of the cost implications and they will be significant."

Sanibel resident John Williams, who was planning to get a building permit within the next two weeks to begin construction on a cinder block house expressed his concern about the council's action. "Besides making a \$350 set of plans useless," he said, "I have to take my old house off the market until I see how much more a piling house will cost."

A local builder said that he felt it "was just one more way to stop building on the Island. The council's action will drive new housing prices up and raise existing house values.

Many people either can't or prefer

not to negotiate a staircase," he said, "so having to put a house on pilings is definitely going to discourage some people from building here. I don't think it was brought up fairly because people didn't know it was going to be discussed."

Bill Frey, president of Sanibel Homes, said a piling house will point cost 30 percent more but pointed out that there were advantages. "Putting a house in the air gives you the area underneath for a garage or boat that you don't really pay for. And there is better ventilation in a piling house," he said.

In response to calls from residents about the council action, it has been rescheduled at the joint Planning Commission City Council workshop, Tuesday, July 25.

"I think perhaps we were a little hasty," Sanibel Mayor Zee Butler said Monday. "The attorney has problems with this action," she continued, because it was done without proper notice and public hearings. I would hope on July 25 that we would rescind the elevation standards and let it remain as it was until after the 90-day appeal period is over.

city hall: no decision yet

State Attorney Joseph D'Alessandro has had the report from the Lee County Sheriff's Department about alleged irregularities in city hall, but as of press time, there was no announcement about whether or not, he intends to dismiss the complaints or take further action. D'Alessandro just returned from a week's vacation in Palm Beach where he did review the report.

Why 'high wheels'?

High wheel power mowers were developed (and patented) by Anthony Sarlo back in 1935 for one simple reason...to make it easier to cut the grass here for a nice lawn. Through laws of physics, bigger diameter wheels roll easier than small diameter wheels, particularly in Florida's soft, sandy turf. Sarlo's original mowers had simple, functional design with welded heavy duty steel frame for durability and easy repair. Today's Sarlo High-Wheelers have the same advantages. That's why it's smart to get a Sarlo High-Wheeler for your lawn cutting. Ask the woman who uses one!



Sarlo Manufacturing High Wheelers Since 1935

SARLO POWER MOWERS, INC.
P.O. Box 1169 • Phone 813-332-1955 • 2315 Anderson Ave. • Ft. Myers, Fla. 33902

CLIP AND SAVE



BACARDI LIGHT RUM

5⁷⁹ QT.

Reg. 6.89
Limit 3

OFFER EXPIRES FRIDAY, JULY 28

Open 9am-9pm 1201 Periwinkle Way 472-3333

R-B LIQUORS

Discount Liquor Prices
(Quantity Rights Reserved)

CLIP AND SAVE

VILLAGE EMPORIUM
Jewelry and Imported Gifts

SALE
Check our Prices.

See Life 24 Kt. Gold and Silver
Electroplated Jewelry, Incl. Stickpins

14kt. Gold Chains, Bracelets and Earrings
Lapis, Melicate and Ivory Necklaces

OPEN 11 AM TO 9 PM Behind Scotty's Pub

The Owl and The Pussy Cat
LOCAL ART GALLERY

Presently featuring

Larry Hoff
and
Linda Ritchie

Summer hours 10-5
Metal Sculpture

CAPTIVA, FLORIDA 33924
TEL.: 472-4974

Island Financial Services
(Financial Planning & Management)

provides

- bookkeeping and accounting for shops, motels, condo associations, partnerships, and corporations including
- budget preparation, financial statements and financial analysis as well as
- income tax preparation by **H & R BLOCK**

Sanibel Center Building, 1711 Periwinkle Way,
PO Box 194, Sanibel, Florida 33957
(813) 472-1439 Elliot Gelberg

SALE!

30% Off
OUR ENTIRE
LINE of LADIES
GOLF SETS
and
DRESSES
SELECTED BLOUSES
30 to 50% OFF

**BARGAIN ROOM
SPECIAL
BLOUSES \$5.00**



THE **Sand Dollar**
959 ESTERO BLVD.
FORT MYERS BEACH

THE ONLY PLACE TO SHOP

commentary

emergency medical service

Imagine if you will, the following situation. You are attending a city meeting and the issues get, as they often do, very controversial. The person next to you is engaged in a heated argument and then suddenly slumps over, the victim of an apparent

attack. Quickly you call the medics, who arrive in seconds, and find that they are required to administer cardiac pulmonary resuscitation. But perhaps the patient has complications and hospital is the quickest and best answer. The closest hospital

emergency room is Cape Coral and they have fine facilities.

O. K. You are air borne but you must go to Lee Memorial Hospital even though it will take a helicopter an extra three-four minutes and a ground unit about 15. A minute or two away from landing, the patient dies.

Such a scene sounds impossible, but it could happen if the Lee County Commissioners, who control our Emergency Medical Services (EMS), decide to approve a plan proposed by Lee Memorial Hospital. The hospital has offered to staff the EMS program if the county agrees to have all emergency patients who have been monitored by radio contact transported to Lee Memorial's emergency room for treatment.

Last week, at their regular meeting, the Commissioners decided to appoint a committee to study the proposal. We presume that decision was made because new state regulations with respect to ambulance service will force the county to spend an additional \$70,000 in the coming fiscal year and

Lee Memorial's proposal could save the county that much money.

The Florida Legislature has required that any ambulance service using paramedics to perform life-support procedures must have a physician as a medical director. Lee Memorial has offered to provide a medical director for the ambulance service and all newly required medications for the ambulance. The problem is that once a Lee Memorial doctor has begun treatment, or the use of telemetry has been started, the ambulance must then transport that patient to Lee Memorial hospital, even over the patient's own objections.

It is true that such a plan would obviously provide a service to the county and to Lee Memorial. But what about the patient? What happens if, in the case of several of our Island residents who have heart conditions, their doctors are at Cape Coral Hospital? Or Lee Community? It seems that Lee Memorial is playing

cont. on page 5

letter to the editor

My dear Editor:

The ISLANDER'S Kay Pratt wishes to congratulate the other Kay Pratt who recently received recognition in the ISLAND REPORTER for having received her degree in nursing from the Edison Community College.

In her day, this writer has wanted to be a nurse, and appreciates the unearned credit given her, along with the kidding, because of the identical

names. She has put letters back into circulation addressed to Pamela Pratt but not until this time was the coincidence realized.

We have never met. It would be fun to get together.

Sincerely,
Kay Pratt
Blind Pass Condominium

The **West Wind Inn**
Gulf Drive, Sanibel Island, Florida 33957

**LUXURY LIVING ON THE
SUNNY GULF COAST!**

105 ultra modern efficiencies and motel rooms. All air conditioned & heated. Room phones & color TV, large heated pool. Tennis courts, shuffleboard, putting green, excellent shelling, fishing & safe swimming, tennis, golf.



PHONE (813) 472-1541

Are you waxing your paint job to death?

Wax Great for floors. Murder on cars. Car wax acts like flypaper to dust dirt and pollutants. The imbedded grit can actually harm the paint and wax gets duller by the day. **Ming your car instead.** Ming can put a shine on paint that even new cars can't match. A shine that's brighter than any wax job available (we can prove it with a fast free demonstration). Ming cleans and smoothes your existing paint to a dazzling finish... without polishes, paints or coatings. It's a durable shine that never needs waxing. A protective shine so slick it actually resists dirt. Ming protects you, too, with a full 3-year guarantee. If you decide to sell your car, you can sell your Ming guarantee right along with it. Phone or drive in to your Ming Auto Beauty Center soon. Because your car needs another wax job like it needs a hole in the hood.



**THE FULL CIRCLE
OF AUTO BEAUTY**
4248 FOWLER AT EAST MALL DR.
FORT MYERS, FLORIDA 33901
(813) 939-1440
OTHER FLORIDA LOCATIONS:
NORTH MIAMI, FLORIDA 33162
(305) 944-1222
LAUDERHILL, FLORIDA 33313
(305) 587-6450



936-0034

GRAHAM
DRAPERY & SHADE

verticals
by Graber®

DECORATIVE/
FUNCTIONAL

A complete window treatment... made here.

Vertical Blinds, Window Shades & Draperies made to order from our in-stock materials.

Ask about our "Immediate Delivery."

BUY DIRECT FROM MANUFACTURER!

5532 U.S. 41 SOUTH - FT. MYERS

Just South of Airport -
Across from Dragon Plaza

Experienced in Decorating needs of Southwest Florida since 1960.





SANIBEL-CAPTIVA
Islander

Established 1961

Editor Gwendolyn J. Stevenson
Advertising and Business Manager Steve Sherman
Production Manager Bonnie Evenson

— ADVERTISING —

classifieds: All classifieds appear in the Sanibel-Captiva Islander, Fort Myers Beach Bulletin, and Bonita Bulletin. \$1.00 for first 10 words, 5¢ each additional word. Boxed ads in classifieds section \$1.00 extra. Mailing address: P.O. Box 2867, Fort Myers Beach, Florida, 33931.

— WHERE TO CALL —

news items	472-1881; 472-1418
classifieds	463-4421; 472-1881
subscriptions	549-0123; 472-1881

— DEADLINES —

classifieds: Mon., 12 noon.
news items: Friday, 5 p.m.
display advertising: Thursday, 5 p.m.

— ADDRESSES —

Mailing address: P.O. Box 3, Sanibel, FL. 33957
Office location: 2402 Palm Ridge Road, Sanibel.

Published weekly at 1300 Estero Blvd., Fort Myers Beach, Florida 33931. Price at news stands: 10¢; subscription: Lee County \$5.00 per year, USA; \$8.00 per year; Foreign rates on request. Second class postage permit entered and paid for at Fort Myers Beach, Florida 33931, and at additional mailing offices. Post Master: Send form 3579 and change of address to P.O. Box 3, Sanibel, Florida 33957.

chamber of commerce introduces insurance plan

The Sanibel-Captiva Chamber of Commerce is introducing a group health protection trust available to their members, Chamber Executive Director Walter Klie announced Friday.

Several months ago, the Chamber sent out questionnaires to their members and because of the tremendous response the Chamber proceeded to find a carrier to implement what they had determined were the Islands' insurance needs.

The carrier, Pacific Mutual Life Insurance Company, is ranked within the top two percent (by assets) of the more than 1800 major life insurance companies in the country, Klie said in a

recent statement to the members.

The agent, Bill Beardon of Insurance Management Corporation in Fort Myers, is developing a kit outlining all the details of the package -- which is available to businesses with two or more employees -- and should be available within the next week or so.

"While the program is voluntary," Klie said, "we hope that as many members as possible will support it."

post office contract awarded

Hegeman-Harris Co., Inc., P.O. Box 1345, Melbourne, FL 32935, was awarded a contract to build the new main post office building in Sanibel, Postmaster A. P. Adams said here.

The contract was \$369,500, the lowest of two bids received.

The proposed new postal-owned building will have approximately 5,336 gross sq. ft. of interior floor space. It will be located on a one and one-half acre tract of land on the south side of Lee Road between Tarpon Way Road and Braw Avenue. The site was purchased in August 1977 for \$147,000.

Project architect is Fenton, White Associates, 2075 Periwinkle Way, of Sanibel.

The building is expected to be completed in April 1979.

commentary

from page 4

games for patients at what may be the expense of patient lives.

Our Emergency Medical Service Program is generally acknowledged to be superb. The letters to the editor that the newspaper receives in praise of the EMS technicians who perform coolly and competently under the most stressful of situations, are legion. But it should be up to their evaluation of a medical emergency and-or the patient's own wishes about which hospital he prefers that are the deciding factors. We hope that the county commissioners and the committee studying the problem keep that in mind.

obituary

Suzanne Boiet Lasak, 35, of Stowe, Vermont and Sanibel, Florida, died on July 14 in Stowe after a short illness. She and her husband, Martin Lasak had owned Silver by Lasak in Periwinkle Place for many years before returning to spend full-time with

a similar shop in Stowe.

She is survived by her husband, Martin, her parents, and a brother, all residing in Canada and a sister in Burlington, Vermont.

Buriel was in Stowe on July 17.

Fresh Seafood Market

at the
the real eel



FRESH SHRIMP
SNAPPER
OYSTERS
SCALLOPS

GROUPE
MACKERAL
CLAMS
STONE CRAB CLAWS
FLORIDA LOBSTER

Complete Sports Center

scuba air station and rentals
bait, rods, reels, fishing tackle
tennis and water skiis

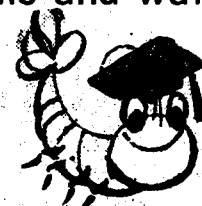

home of
the
educated
shrimp

SANIBEL CENTER BUILDING
PERIWINKLE AND CASA YBEL ROAD

SKIP PURDY
472-2674

BAILEY'S GENERAL STORE

Island Shopping Center, corner Periwinkle and Tarpon Bay Roads

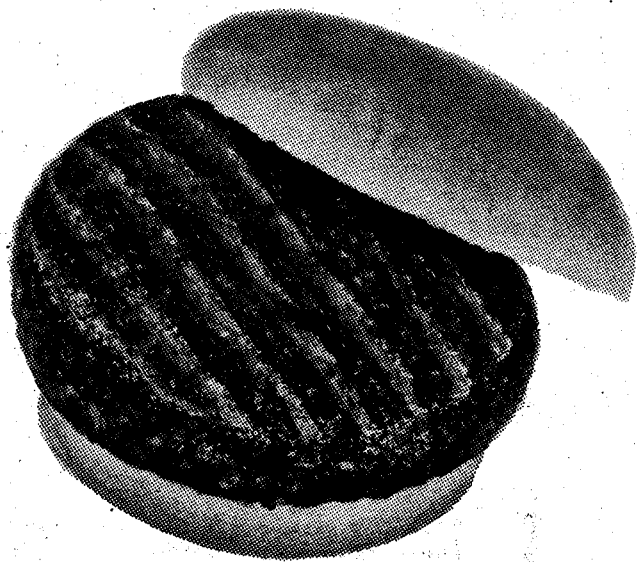

Oster Sizzle Grill

Jumbo Sandwich Maker
Cooks almost anything in 1 to 3 min.
Non-splatter coverlock
Extra easy to clean
Cooks round on one side
and square on the other.

Regular \$19.94 **NOW \$17⁹⁴**

BAILEY'S
GENERAL STORE

Groceries - Meat Market - Produce - Hardware - Fishing Tackle
Dry Goods - Sportswear

Beachwear

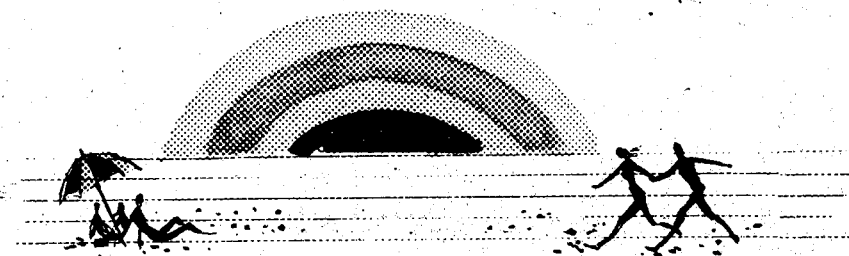

Ladies Swimsuits
Beach Towels
Angel Tread Beach Shoes
Men's Swim Trunks
Cabana Sets

BAILEY'S
CLOTHING CENTER

Island Shopping Center (next to the Gray Shop)

in your opinion

What do you think
about the city's six month moratorium
on multi-family building permits?



I'm not in favor of it. Carolyn Underritter



I think it's a wise idea. Elaine Humphries



I think it's a good idea. It's better to keep from getting too many people on Sanibel, keep it from becoming like Miami Beach. Jennifer Mitchell



I think it's ridiculous to put a moratorium on for just the short time it should take the council to consider the two bills. They should either pass them or reject them, but not put on a moratorium. Gene Francis



I'm in favor of anything that will slow down growth. I think the main problem's water. We're drawing too much water from the aquifer, and it's got to come to an end. John Goodro



I love it! Dave Roughead



I don't really approve of it. We've got a Land Use Plan, let's stick to it. John Gayle

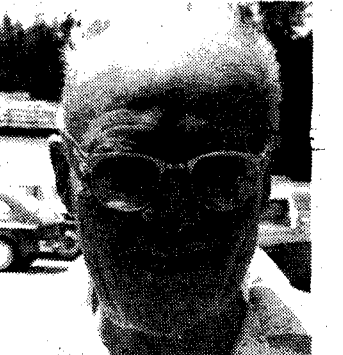

I think it's great. It's getting so you can't even go to the beach anymore. There's no place to park your car. Edward Kelly

THE VACATION COMPANY

VACATION RENTALS

If you are planning to visit our islands for your winter vacation, why not let the professionals in condominium vacation rentals assist you.

Sanibel Accommodations rental manages many privately owned and elegantly furnished condominium homes. Each is complete to the last detail and is made available for your rental pleasure.

Our condominium homes range from efficiencies to three bedroom/two bath apartments and offer amenities such as heated pools, tennis, sailboat and bicycle rentals.

For your most memorable vacation ever, just contact Sanibel Accommodations for our free brochure.

**SANIBEL
ACCOMMODATIONS**

A division of
JOHN NAUMANN & ASSOCIATES INC.
P.O. Drawer W
Sanibel Island, Fla. 33957
Tahitian Garden
(813) 472-3191



Professionals in
condominium sales,
re-sales and rental
management.

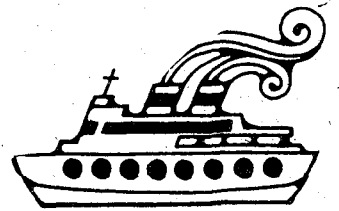

**ANNOUNCES
TWO ESCORTED
CRUISE SPECIALS
FROM SANIBEL**

**M/S SUNWARD II
BAHAMARAMA
CRUISE**

DEPARTING: OCTOBER 20
3 DAYS - 2 PORTS
\$298.00 Per Person
(double occupancy)

Escorted from Sanibel to Nassau & Berry Islands by Sherry Vartdal

**EMERALD SEAS
THANKSGIVING
HOLIDAY
CRUISE**

DEPARTING: NOVEMBER 20
4 DAYS - 2 PORTS
\$349.00 Per Person
(double occupancy)

Escorted from Sanibel to Nassau & Freeport by Paula Goodman

Special Cruise Rate Includes:

Roundtrip bus transportation between Sanibel and your ship
Deluxe 2 berth outside cabin
Port taxes
Interval cocktail party
Travel accident & sickness insurance

Space is limited -- so make your reservations now.

Phone: 472-3171
Interval Travel Agency, Inc.
1618 Periwinkle Way Sanibel

"wish list" presented to county commissioners

During last week's regular meeting of the Board of Lee County Commissioners, a preliminary budget calling for a nearly 11 percent increase in county spending was presented by County Auditor Sal Geraci. The budget should be regarded as a "working tool," Geraci said, cautioning that it represented what each county department would like to have in their coffers for fiscal 78-79. As it stands now, the budget represents a millage rate of 10.604, which is above the legal limit of 10 mills, if the county wanted to meet all the requests by county departments.

Geraci told the commissioners that the budget proposal is based on last year's property valuations, and until

County Tax Assessor Harry Schooley presents current valuations and estimates, "how a true estimate of the tentative budget can be made...is not understandable to me."

Schooley has told at least one member of the county legislative body that county tax revenues could be expected to increase as much as 19 percent over the \$17 million in property revenue for this fiscal year.

County Commissioner Doug Taylor characterized the budget as the "wish list" of all county departments and that will be pared down considerably."

The budget presented by Geraci would require more than a 38 percent increase from the year's current tax millage of 7.276. A mill is a \$1 tax on

each \$1,000 of taxable property.

Geraci said that with a 20 percent increase in ad valorem tax revenues, the proposed taxing rate could drop to an estimated 8.2 mills, which would still represent a 10 percent increase over this year.

Geraci's proposed wish list represents a 10.8 percent increase in the current operating budget and does not include any new employees or programs except those proposed by constitutional officers.

Geraci's tentative budget includes: -An \$18 million revenue bond issue with corresponding appropriations for the construction of a new jet airport. This item accounts for 55.95 percent of the \$32 million airport budget.

- \$109,769 increase in the Municipal Service Taxing Unit (MSTU) fund because of a house numbering project in unincorporated areas and Planning Department increases. The current fiscal budget calls for a millage of .206, for \$1,168,477.24. The proposed 9.39 percent increase would raise this to \$1,278,246.28.

-A decrease of 23.34 percent in the Sanibel Causeway budget. The 1977-78 budget calls for \$751,939.29. The proposed budget is asking for \$576,454.65.

Because of the "seriousness caused by the size of the budget," Geraci quipped to the commissioners that "most of us find our ambitions nipped in the budget."



GARAGE DOORS & ELECTRIC OPENERS
936-2500
 Wood - Fiberglass
 Steel - Woodgrain
 Sales, Installation
 Service
 Residential
 Commercial
MOREOMATIC
 Door Openers
 2016 Beacon Manor Dr.
 Ft. Myers, Fl.
 Roy North, Owner

One Stop Shopping

- ☆ 75 Brands of Beer
- ☆ 750 Wines
- ☆ Film
- ☆ Film Processing
- ☆ Famous Seafood Subs
- ☆ Groceries
- ☆ Gift Department
- ☆ Famous Amos Chocolate Chip Cookies
- ☆ Exclusive Charles Chips in a can
- ☆ Delicatessen
- ☆ Catering
- ☆ Convenient Hours

BHIVE

OPEN
 9-8 Sun. thru Thurs.
 9-6 Fri. and Sat.

2407 Periwinkle Way - Sanibel - 472-1277

HOURS 10-5

THE RED PELICAN
 SANIBEL ISLAND
 FLORIDA

Hand made Turkish blouses

Next to Tarpon Bay Marina
 472-4449

HAND CRAFTED GIFTS CRAFT SUPPLIES

Black Pearl

HOURS: 10 TO 5 CLOSED SUNDAY
 2365 PERIWINKLE WAY, SANIBEL ISLAND

Fresh Seafood Market
 at the *the real eel*

FRESH SHRIMP
 SNAPPER
 OYSTERS
 SCALLOPS

GROUPE
 MACKERAL
 CLAMS
 STONE CRAB CLAWS
 FLORIDA LOBSTER

Complete Sports Center
 scuba air station and rentals
 bait, rods, reels, fishing tackle
 tennis and water skis

home of the educated shrimp

SANIBEL CENTER BUILDING
 PERIWINKLE AND CASA YBEL ROAD

SKIP PURDY
 472-2674

ZAMBOANGA

SHELL LAMP

\$39.95

Complete

Just Add Shells

We Ship Anywhere

at Tahitian Garden
 Periwinkle Way
 10-5 Mon.-Sat.
 472-4035

HOME FURNISHINGS

MOPED AND BICYCLE RENTALS
 BUDGET RENT A CAR

The Cycle-logical way to see the Island
 OPEN DAILY 10:00 A.M. TO 6:30 P.M.

ISLAND MOPEDS
 1470 Periwinkle Way, Sanibel, Fla.
 Phone 472-5248

commission suggest palm fronds for beach renourishment

When the Planning Commission reviewed the Capital Improvement Budget in session with the City Manager several weeks ago, Commission Chairman Ann Winterbotham expressed concern about the \$47,500 allotted for bay beach renourishment. Mrs. Winterbotham suggested to City Manager Bill Nungester that the same project, that of renourishing the Bay Beach front, could be accomplished "almost free," and explained that she was referring to Elinor Dormer's experimental renourishment project of holding sand on eroded beaches with palm fronds embedded along the water line.

Last spring, a crew of volunteers and Comprehensive Employment Training Act (CETA) workers joined Mrs. Dormer in her effort to retard the erosion along the Bay side of the Island. Other residents of Bird Lane have joined Mrs. Dormer in her belief that this method of restoring eroded sand beaches (that they have used for many years in front of their own water

front homes) could work as well on the Kuder property, now owned by the Sanibel Captiva Conservation Foundation.

Since that time, wave action has continued to lap at the Kuder beaches, but Ellie Dormer's experiment seems to be working. At low tide, it's easy to

see that sand has been trapped among the fronds of the palm branches and restored to the beach. The roots of a sabal palm, which only a few months ago were exposed to the air because of erosion, now have a comfortable layer of sand banked beneath them.

Mrs. Dormer visited recently with Bill Byle, a biologist who lives in Alva and is presently employed by Keith Trowbridge to study the erosion from the Lighthouse along the Bay side to the Causeway. Mrs. Dormer was pleased with Byle's reaction to her experiment.

"He was surprised and pleased," Mrs. Dormer said.

Currently, Mrs. Dormer is hoping to apply her palm frond method to a section of beach on Woodring Point that has also suffered from erosion. Island residents who have palm fronds to aid in the effort can deliver them to the site, which is clearly marked, or call Mrs. Dormer at 472-1664 for directions to the spot.



The Affordable Luxury Vacation Is Here

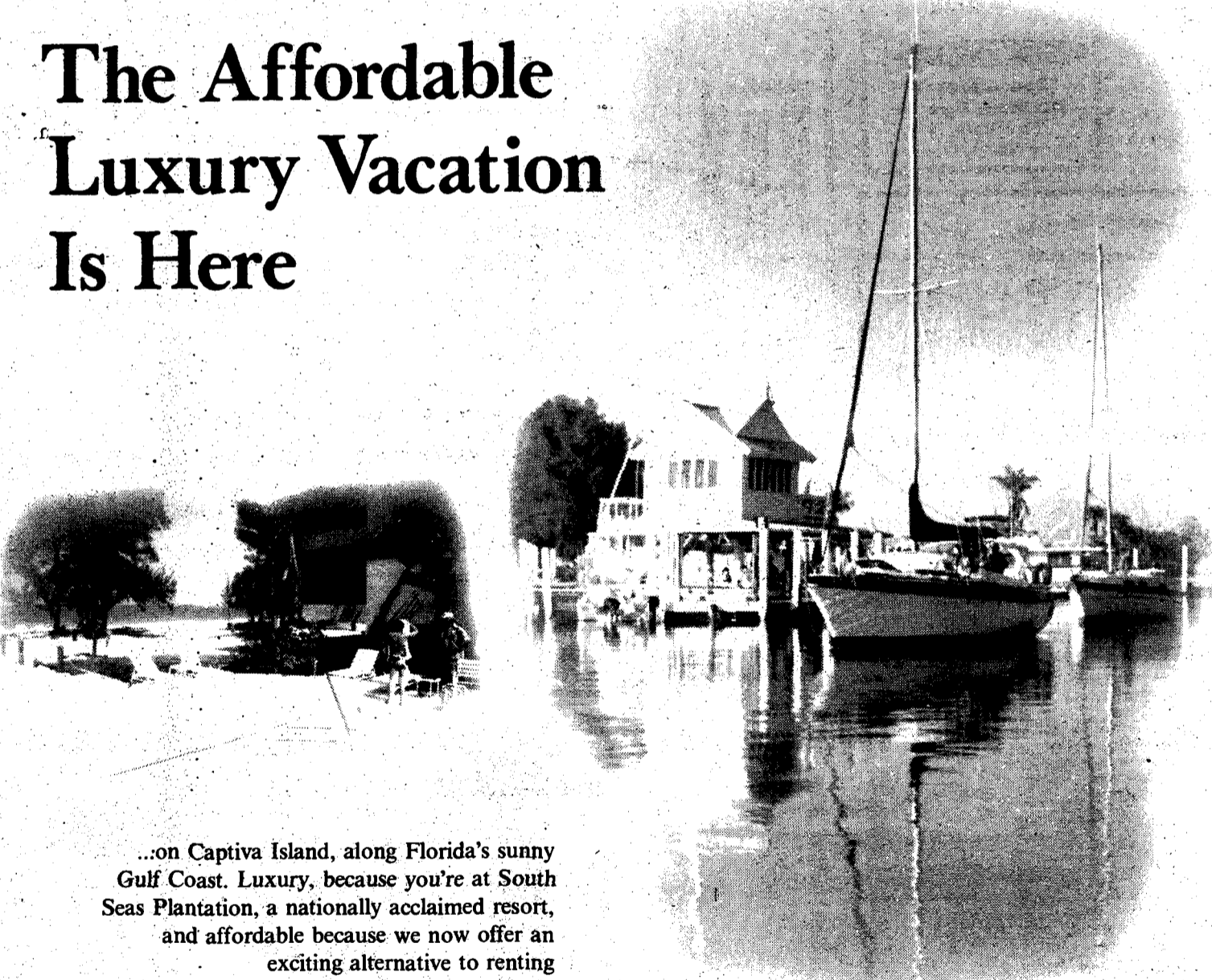

...on Captiva Island, along Florida's sunny Gulf Coast. Luxury, because you're at South Seas Plantation, a nationally acclaimed resort, and affordable because we now offer an exciting alternative to renting vacation accommodations.

South Seas Plantation is an exclusive island resort where the lifestyle revolves around miles of secluded Gulf beach, a championship-caliber golf course, fine dining, dancing and entertainment, a superb new tennis center and fishing and boating from our deep-water yacht basin.

You'll also find Plantation Beach Club, where Interval Ownership allows you to match vacation home ownership to just the weeks of the year you desire, offering you a sensible way to afford luxurious island vacations, forever.

Fully furnished and equipped 2-bedroom, 2 bath, vacation villas directly on the Gulf beach begin at \$2,500*. See Plantation Beach Club soon, at South Seas Plantation on Captiva Island.

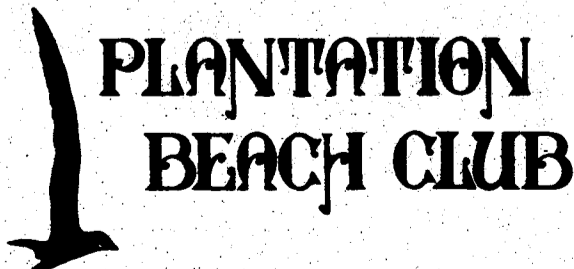

*Prices subject to change without notice.
For the colorful details and hard facts about Interval Ownership at South Seas Plantation, write:
Plantation Beach Club • P. O. Box 217 • Captiva Island • Florida • 33924 or phone (813) 472-4435.

on the water by mike fuery

The Island Air Resort International was the location of a joint meeting of the Nude Fishers Society (NFS) and the Totally Exposed Shellers Union on Sanibel Island this week.

I covered that revealing meeting for The ISLANDER and this week we will have a peek at two unusual groups of people devoted to fishing and shelling in its purest form.

First of all, I don't often get invited to such meetings. I get asked to cover fish fries, third rate catfish catching contests, but never a convention where the warmest thing a person has on is a tile.

It was a two-day conference and when I got the written invitation in the mail a few days before, I was amused to note that over the front of the agenda in bold letters posed the question, "Why hasn't a world record sized marlin been caught by someone in the nude?"

And, on the back of the same agenda card, was another query to make the mind ponder. It asked, "God intended for you to go shelling in the nude. That's why he didn't sew a pouch on your stomach to allow you to take more than 40 shells at a time." Thought provoking.

Anyway, I arrived at the island resort, and realized that when you cover such a meeting there is no lapel to provide a place for your identification card. That's because there is

no lapel and no nothing on anyone for that matter. I called the office and told them to rush over a small camera.

The International Nude Game Fish Association had a speaker open the meeting. There was a ten minute break between presentations so when Warren Coats finished his speech I got a few words with him. Here's part of what Coats had to say about fishing.

"Naturally, buff fishing is more of a challenge than the other way. First of all, you have the sun to contend with, but the wide use of fighting belts has saved many newcomers to the sport, if you know what I mean," Coats said.

"Those new big game rods with cold metal handles aren't as popular as they once were, either. But that's emphasizing the few minor drawbacks. You have to remember that wading in a quiet trout stream, casting your fly

er...casting your lure up stream, is a pleasure few people on earth have enjoyed since the advent of clothes.

"There is something thrilling about posing stark naked beside a equally nude tarpon after a long battle. It strips away the pretense of clothes. It's fishermen against fish. That fish doesn't care if you are wearing Cardin or Johnny Carson clothes. You and that big game fish are wearing the same outfit—just what God gave you. Man, that's fishing at it's best!"

But, aren't there laws against fishing in the nude? I don't think you can go

nude surf casting on Sanibel's beach, for instance," I asked.

"That's what this conference is all about. We are going to fight to get new laws on the books making it legal to wet a hook and fish without clothes. We are going to get on the agenda of the City Council as soon as possible."

"Are you going to wear clothes to the meeting with the city?"

Coats shook his head. "That would be an act of two fac-ism to appear at such a meeting wearing clothes, as far as I'm concerned."

Coats directed me to a young woman, standing in the middle of a group of men discussing shelling. I signaled her that I wanted a few comments for the paper. She wore a shark's eye shell on a chain around her neck, giving me the impression that she was an Anne Boleyn look-a-like. She was very knowledgeable about nude shelling and was President of the Texas delegation. I found that everything from Texas is bigger than life. Anyway, here is part of our conversation.

"Naked shelling is the superior form of shell conservation. With only two hands to hold 'em you can't take hundreds of shells. Not one of our members would dream of bringing a shelling bag. It's a healthy way to get exercise too."

"Is there a future for nude shelling?" I asked, trying to keep my eyes on my note pad.

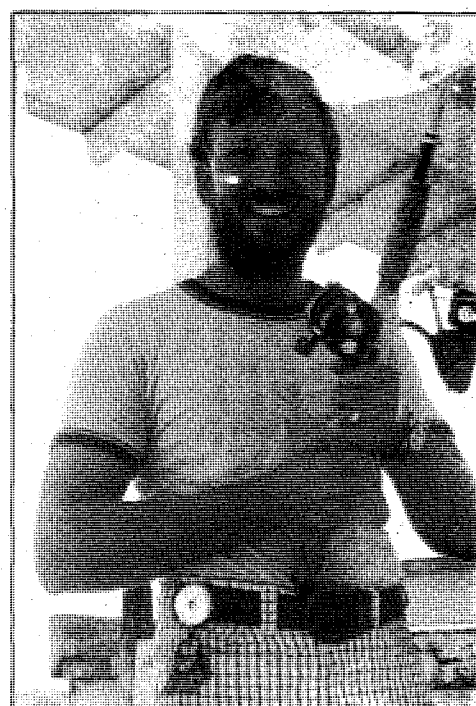

"I'll tell you this. If you want to preserve your shells here on the islands, make it a law that you can't collect a shell while wearing any clothes."

"Are you going to go before the council too?" I asked.

"Of course. There are about 50 of us going, naturally. You coming to the Meeting?"

"I wouldn't miss it for anything. And just when the council has a new meeting room, too."



MANPOWER TEMPORARY SERVICES has arrived in Fort Myers, FL

Manpower has opened a new office in Fort Myers, FL to bring you the best in temporary help. Now, whenever you need dependable professional office help like secretaries, typists, clerks, bookkeepers or marketing assistance for product demonstrating, detailing and sampling, you'll always find them at Manpower.

Vacations, absenteeism, peak seasons... any time you have too much work and too little help, give us a call. We're proud to be here and anxious to help.

MANPOWER
TEMPORARY SERVICES

332-4677
2211 Fowler Street
Fort Myers, FL 33901

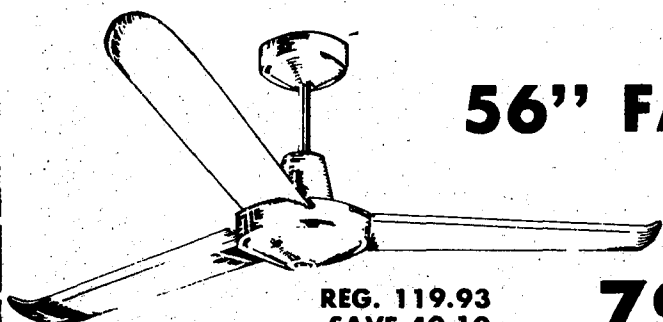

56" FAN

REG. 119.93
SAVE 40.10 **79.88**

Cool your Florida room, patio or den with this three blade ceiling fan. Five slow-to-fast speeds give room comfort for only pennies a day. Heavy duty aluminum, 110 volt. Enclosed motors. White enamel can be spray painted. These 56" fans can be installed 5 ft. from ceiling or 12" by cutting rod. also at bargain Center.

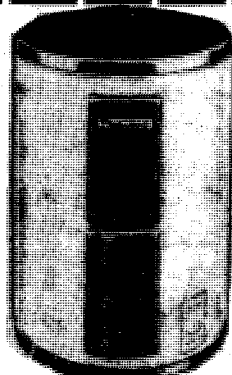

**20 GALLON
GLASS-LINED
WATER
HEATER**

\$78.88
Reg. Disc. \$88.98
SAVE \$10.10

A brand name electric water heater. Thickly insulated to reduce heat loss. 5-year written warranty on tank. 110 or 220 volts. 1500 watts, 19" wide, 27" tall. Attractive. Dependable. We have many water heater sizes.

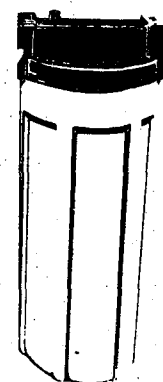

**AMETEK
FILTER**

REG. 21.98
SAVE 5.10 **16.88**

The guaranteed cartridge filter measuring 12" x 5" diam. will bring an amazing improvement in your drinking and cooking water. Easily installed under the sink or in utility room with quick connect fittings. Get spring-like water without expense of buying it. Filters are interchangeable in cartridge.

LAUREL'S

DISCOUNT DO-IT-YOURSELF CENTERS
LAUREL'S GIVES ADVICE & PRICE

7 1/2 Miles North of Ft. Myers Bridges on Rt. 41 Near Lee Charlotte Line

OPEN MON.-FRI. 8:30-5:30 SAT. 8:30-12:30

CLOSED SAT. P.M. & CLOSED SUN.

995-5043 • 995-8290 • 995-0809

BARGAIN CENTER - 2216 ANDERSON AVE. - 334-7259

LAUREL'S COUPON

**SECURITY
SMOKE DETECTORS**
REG. 26.99
SAVE 7.11 **19.88**

Very sensitive. Protect your family and property. Be warned of fire danger BEFORE heat develops. Senses smoke and warns you quicker than flames or thermal warning devices. Emits shrill siren. 110 volts. Also at Bargain Center. #081-612. These are U/I approved.

1 - Electric 26.99 Sale 19.88 Save 7.11
1 - Battery 31.99 Sale 22.88 Save 9.11

LAUREL'S COUPON

**20TH
CENTURY
BALL COCKS**
REG. 4.99
SAVE 1.11 **3.88**

New type toilet flusher. No float and rod arm. Shut-off is fast and positive. Provides exact water control. Corrosion resistant and easy to install. Fits most tanks. Also at Bargain Center.

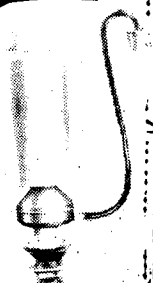

refuge wants comment

Officials from the J.N. (Ding) Darling Wildlife Refuge are soliciting public comment on the construction of pump facilities on the wildlife drive.

A three-way pump is planned for construction along to Drive to transfer water from the estuary side of the dike to either of the fresh water ponds, to pump from either pond into the other or to pump fresh water from either pond into the salt water side.

The officials say that initial construction will cause some destruction of dike-edge vegetation and water turbidity will be heavy at times in the immediate construction area. Both adverse impacts are expected to be temporary.

The pump will enable the refuge to pump out excess water after the heavy rains and so minimize red mangrove kills like those that occurred in 1977. The pump will also control brackishness in the fresh water ponds and allow more interchange of nutrients between the fresh water pond and the estuary.

The proposed construction would conform to all State and local flood-plains protection standards and to the requirements of Executive Order 11988 and 11990.

The Refuge would like to have your comments. Call Del Pierce at 472-1100.

wise guide

a guide to island shops and services

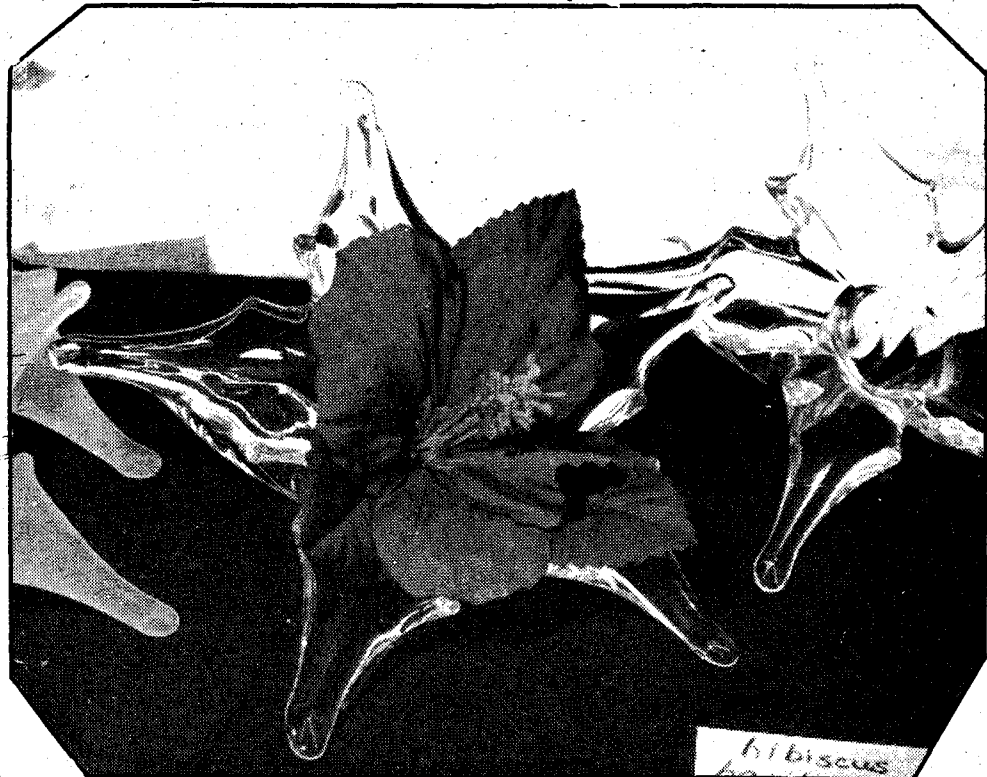

This unusual blown glass flower holder by West Virginia artist Robert Haymond is available at Larry and Nancy Van Til's "House of Treasures" located in The Heart of the Islands shopping center, 1622 Periwinkle Way.

FABULOUS CLEARANCE ORIGINAL OWNERS BACK AT DOROTHY'S SEWING CENTER

Come In And See Don — Dorothy & Patsy

**SEWING MACHINES
GREATLY REDUCED**
WE WILL GIVE YOU A
CABINET OR TABLE
AT OUR COST — PLUS FREIGHT
ALSO
CLASS ROOM AND DEMOS
AT REDUCED PRICES

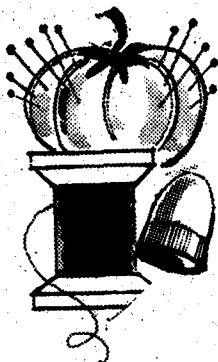

COATES & CLARK
DUAL DUTY THREAD
8 spools for \$1.00
BUTTONS 5 cards for \$1.00
ZIPPERS — Any Size f for \$1.00 5 for

Large Selection of
POLY & COTTON
T-SHIRT KNITS
\$1.49 Yd.

ALL LINGERIE FABRICS
Reg. \$3.98

\$5⁰⁰ per dress (Any size while it lasts)

SMOCK DRESS FABRIC
60" long
STRETCH TERRY FABRIC
Reg. \$5.99
NOW \$2.49

NOW \$2⁹⁸
DRESSMAKING — ALTERATIONS
SEWING MACHINE REPAIR
BUTTON HOLES MADE AND
BUTTONS COVERED

FREE Scissor Sharpening
FOR THE FIRST PAIR WHILE YOU
WAIT. EACH ADDITIONAL PAIR 50¢

Dorothy's Sewing Center

OPEN 9:00 A.M. TO 7:00 P.M. DURING SALE ONLY

5605 Dragon Plaza

936-8738

Fort Myers

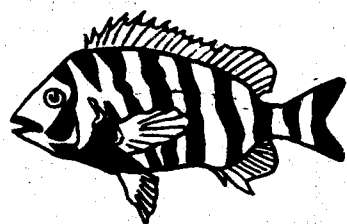

**GOING SOUTH THIS SUMMER?
BIG SAVINGS FOR SANIBEL
ISLAND VISITORS •**

20% TO 45% BELOW
AIRPORT AREA PRICES.
ALL NEW 1978 CARS — A/C,
AUTOMATIC, POWER STEERING
AND BRAKES.

FREE PICKUP AND RETURN
CALL OUR BLUFF
WRITE OR CALL FOR
DETAILS AND RATES

CAPE CORAL RENT-A-CAR, INC.

P.O. BOX 291

CAPE CORAL, FLORIDA 33904
813 - 542-2025 DAY OR NIGHT

summer is for softball

SCORES

Tuesday, July 18

Bailys 11 IWA 17
Island reporter 4 Lions 6
Nave 11 Top of the Mast 6

Thursday, July 20

Captran 0 Top of the Mast 10
Nave Plumbing 12 Baileys 6
South Seas 13 Lions 11

SCHEDULE

Tuesday, July 25th

Lions vs. Top of the Mast 6:00 p.m.
IWA vs. Nave Plumbing 7:30 p.m.
Captran vs. West Wind 9:00 p.m.

Wednesday, July 26

Truckers vs. Sea Fillies 6:00 p.m.
Kennys vs. Supremes 7:30 p.m.
Island Girls vs. Foxes 9:00 p.m.

Thursday, July 27

South Seas vs. IWA 6:00 p.m.
Lions vs. West Wind 7:30 p.m.
Island Reporter vs. Nave Plumbing 9:00 p.m.

Sunday, July 30

South Seas vs. Island Reporter 1:00 p.m.
Casa Ybel vs. ESI 2:30 p.m.
Top of the Mast vs. Baileys 4:00 p.m.

In Sunday softball, the Island Water Association (IWA) beat West Wind 11 to 8. IWA exploded for nine runs in the third inning to take an 11 to 1 lead and then didn't score for the remainder of the game. Oscar Gavin hit a two-run homer for West Wind.

Captran, still winless in 15 tried tries, lost again Sunday to South Seas Plantation 7 to 4.

The Island Girls beat Kenny's 10 to 8 in a game shortened to five and a half innings by rain.



Oscar Gavin does it again, a two run homer.



Stacy Way slides in under the tag of Fran McClintock.



Richard Akers grabs one

photos by tim harris

24 HOUR MEDICAL ALERT!!
at the push of a button!
Carry the panic button in your pocket or purse.
As little as \$15.00 per month plus installation.
Call today for further information
Phone 939-1335

AE ALL AMERICAN ALARM CORP.

COUPON COUPON COUPON

ONE WEEK ONLY! OFFER EXPIRES AUGUST 1, 1978

SWIMMING POOL
MURIATIC ACID 96¢
COMMERCIAL STRENGTH

LIMIT 2 GALLONS WITH COUPON PLUS DEPOSIT

Glamour Pool Supplies
SUPPLIES - SERVICE - REPAIR
5332 S. CLEVELAND AVE. 936-0015-MON.-SAT. 9 to 5
(ACROSS FROM THE HWY. PATROL)

Polly Flinders
FACTORY OUTLET

HAND SMOCKED INFANT & GIRLS DRESSES
FINAL CLEARANCE
SPRING AND SUMMER STYLES

NEWBORN TO SIZE 12

Back To School Dresses Now in Stock

Newborn	\$1.99
Infant	\$1.99
Babies	\$1.99
Toddler	\$2.99
4-6X	\$3.99
7-12	\$3.99

We must! make room for NEW! FALL FASHIONS

5571 SOUTH TAMiami TRAIL
U.S. 41 FORT MYERS (ACROSS FROM PIZZA HUT)
Between Airport & Western Sizzlin Steak House
Hours 10:00 - 6:00 Mon. - Saturday

The Dunes

Is more than a place to live.
It's a way of life.

for lot information contact our sales office in The Dunes Club House
Prices start at \$16,500.

SANIBEL REALTY INC.
Exclusive Sales Representative

"Obtain the HUD Property Report from developer and read it before signing anything. HUD neither approves the merits of the offering nor the value, if any, of the property."

EAST OFFICE: 1207 Periwinkle Way, Sanibel Island, Florida 33957 — Phone (813) 472-1566
CENTER ISLAND OFFICE: 1633 Periwinkle Way, Just East of the Bank, Phone (813) 472-1549 or 1540



Ever think of going into the phone business yourself?

Because your business uses telephone service, perhaps you should consider owning your own telephone system...right? Well, maybe. That is, if you have no better place for your capital dollars and can receive prompt, reliable and economical repair service. Then arrange for the cost of insurance, taxes and the system's replacement due to business growth, obsolescence, damage, or other reasons.

Similar logic might suggest that because your family drinks lots of milk, you might consider buying your own cow...right? Again, maybe...if you know how to feed and milk a cow and are willing to accept responsibility for the

animal's health, daily care, veterinarian's bills and eventual replacement cost of the animal due to age or lack of production.

Some businessmen these days have been talked into owning their own phone systems, without considering all the many ramifications of their decision. (We know. Some of these businessmen have since asked us to buy and maintain their "Private" systems.)

We don't know much about cows, but we do have 77 years of communications experience. We also have hundreds of trained employees, a large fleet of service trucks and we operate a 300 million dollar telephone system, all to serve you better.

So if you want to avoid becoming your own phone company, we suggest you call a United communications consultant when you need advice about telecommunications services and equipment.



**United Telephone
of Florida**

UNITED TELEPHONE SYSTEM

islander angling

by Pacia Field

This sport of fishing can be a serious one and while most of us view it as a means of relaxation there are those fishermen whom we all know who set their goal and progress toward that end with the same determination and execution of plan that they would use when undertaking the construction of a dam.

We are being reminded constantly of the balance or imbalance of nature and this is why I interject here a thoughtful note. Herbst, with the US Fish and Wildlife Service, points out that a "lack of knowledge coupled with poor and careless project planning without regard to the impact on the environment has taken a heavy toll on our wildlife resources. This is why the Endangered Species Act of 73 contains a provision to ensure that environmental considerations are taken into account in the early planning stages of a project. In the majority of cases we can ensure survival of a species by making only minor modifications to a project which might have an adverse impact on the environment." Interested persons who wish to comment on this proposal have until September to do so. Address comments to Director of U. S. Fish and Wildlife Service, Washington, D. C.

On the lighter side - another week of trout - they are being caught everywhere, many in the four and five pound category. Snook, on the other

hand, is occasional, and a few scattered redfish are making their way to Sanibel's kitchens. The Tarpon are really giving the aficionados of that



Jack Primm, manager of the Caribe Inn hooked this 4 ft. 2-inch, 26 lb. Great Barracuda last Wednesday from the "Party Girl" a deep sea fishing charter running from the Tarpon Bay Marina one day a week. The barracuda was caught while drift fishing in about 60 ft. of water 35 miles from shore on an 80 lb. test line.

sport fits by moving about and are no longer localized as they were for a while in our waters. Those of you who want a sure thing will probably have to travel to Boca Grande. A few Cobia are being caught; two new additions to the catches must be mentioned and though they are just moving in I have an idea they may be taking out leases (short term, anyway); they are the flounder and the larger Jack Crevelle. The flounder is an especially fun fish to catch in that he's elusive and acts in

such a way that the fisherman often thinks he has a crab on the other end of his line. Will mention another method of getting flounder after checking it out "legal wise" with the Fish and Game Comm.

We're always amazed at how many fishermen don't care to eat their catch - so - for those of you who like fish but not that "fishy" taste, keep flounder in mind.

In the meantime - good catching - good fishing.

— SAILING ON THE BEAUTIFUL
GULF OF MEXICO —
Deep Sea Fishing

8:00 AM - 5:00 PM
Rod and Reel — Tackle & Bait Furnished
Call for Schedules and Reservations

Tarpon Bay Marina

Tarpon Bay Road
Sanibel — 472-3196



Rob Lippert, Keith Porter, and Bill Porter with their 38 lb. 3½ ft. Cobia they caught last Wednesday

"images" is pleased to announce that the noted California Artist and Interior Designer Shirley Vale will be available by appointment to create your own Special Dream. Ms. Vale is also taking applications for Oil Painting lessons. If you have never painted or want to improve your skill, it's a real opportunity.

DRAPERIES Custom Made BUILDING A NEW HOME?

AND YOUR \$BUDGET\$ IS ALL BENT AND BATTERED —
LET "IMAGES" UNLIMITED JULY SALE
PUT YOUR MIND AT EASE

25% OFF OUR FABRIC AND LABOR ON SELECTED FABRICS. 20% ALL OTHER FABRICS & LABOR

20% OFF ALL MANUFACTURERS SUGGESTED RETAIL LOUVER DRAPE — WOVEN WOODS LEVELOR BLINDS — SHADES

BEFORE YOU BUY ANYWHERE GET OUR ESTIMATE AND SAVE.
We Measure Up
Estimates Made from your floor plans

939-1717
Our Shop-at-home consultants will come to you. No obligation or cost. Ask about our convenient credit plan.

"images"
Unlimited Inc.

5450 S. Cleveland Ave.
(1 block So. of Airport to Pizza Hut)

Ask for KODAK mailers

Convenient Prepaid Processing for KODAK Color Film

- For your slide, movie, and color print film
- Easy-to-use. just drop in the mail
- Your processed films and prints mailed right to you
- Act now and be sure to ask us for KODAK Mailers

WE OFFER
**COLOR
PROCESSING**
by Kodak

1571 Periwinkle Way at intersection
with Dixie Beach Boulevard.
Phone 472 1086

"The hypnotist doesn't have any power...any magic. The ability is in them, not in me."

Alan Densky, Licensed Hypnotechnician

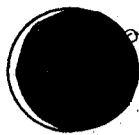

HYPNOSIS

by betsey mallet

The Sanibel Police Department has recently become involved with the use of hypnosis in police work, a practice that has been on the upswing in police departments throughout the country for the past ten years. The Los Angeles Police Department was using hypnosis in the early 70's to induce greater recall in witnesses or victims, but the Sanibel Police Department has only used this law enforcement device one time.

Chief John Butler relayed the circumstances of the investigation in which hypnosis used with a witness revealed more physical details of the criminal involved:

"There was a break in at the Sun Dial Condominium about midnight one night ... a mother and daughter were asleep and a masked man entered the daughter's bedroom ... the mother awakened and struggled with him, but he escaped and details of his appearance were real vague since he wore a mask. Lew Phillips hypnotized the woman involved, and under hypnosis, she revealed greater physical details about the man. She had better recall of the whole incident. We haven't made an arrest yet, but we've sure got more to go on!"

Butler continued: "They've used hypnosis up in Tallahassee with this murder of the coeds case, and gotten better recall from some witnesses. Even from one woman who had suffered brain damage and doctors didn't think she could remember anything.

It's amazing. In Orlando, they've hypnotized witnesses in the courtroom, before a jury, to reveal more details.

Hypnosis ... only in the past twenty years has the science shed its Svengali image and emerged as a responsible and professional method with applications in medicine, dentistry, psychology, psychiatry ... in fact, every area of healing arts and self improvement.

The science is equally hard to define, since no one knows what goes on inside another person's head. We live our day to day lives dealing with our conscious minds - making decisions and critically analyzing each action. But there are some actions that are performed by our bodies that we do not have to think about ... breathing, for example, and blinking our eyes or feeling pain ... and these reactions are handled by our subconscious mind. Hypnosis bypasses the conscious mind, which has the ability to critically analyze outside suggestions, and moves on to the subconscious, which accepts what it is told and reacts accordingly. The state of hypnosis merely allows a subject to become more acceptable of suggestions than he might be outside of the hypnotized state.

Lew Phillips of the Sanibel Police Department is confident of his newly found ability to hypnotize another individual, and enthusiastic of the science. He was one of seventeen men

from a five county area that were selected for training in the use of hypnosis to aid in criminal investigations.

Dr. Larry Hogan, a clinical psychologist with the Cape Coral Medical Clinic met with the police chiefs from Region Ten, a five county area, and requested that these departments select an officer who might be specifically suited for training in the field of hypnosis. Such an officer needed to have at least three to five years in police work and demonstrate an ability to work effectively in an interpersonal relationship. Following a personal interview, each trainee was then given a psychological test. The results of this intense screening were the seventeen men who entered into a three day intensive workshop and a subsequent supervised "polishing" program for four months after that.

"We were very surprised," said Dr. Hogan, "that we didn't have any wash outs in the program. We reserved the right to ask any one of them to drop out at any time. We were hesitant and cautious. I think we did a good job of selecting the right men."

Sanibel partolman Phillips learned while working with Hogan and Harry Roberts, a former New York State Trooper, who also worked in Dade County, that hypnosis has been used for the last eight to ten years in police work and that almost every major police department in the country uses hypnosis to aid investigations. The value of hypnosis for policemen is that in they

hypnotized state, a subject has the ability to recall events in greater detail. Hypnosis can only help an individual recall items that must then be substantiated through additional supportive evidence.

Hypnosis does not necessarily increase truthfulness, added Dr. Hogan, but it very often produces additional potential leads that must then be confirmed. Hogan indicated that police departments will either hire a trained professional to work on specific cases or full time, or train a selected officer within the department in the field of hypnosis. In the case of the Sanibel Police Department, both Chief Butler and Lew Phillips have received such training.

We visited with a professional hypnotechnician in Fort Myers to learn more about other uses of hypnosis. He is Alan Densky, and is one of a very few licensed hypnotists in Lee County. Densky received his training in Hallandale, Florida, at the Hypnosis Consultation and Training Center, one of ten centers in the United States certified by the Association to Advance Ethical Hypnosis. Densky also has some 680 hours in basic law enforcement training and worked on the police force in Collier County, but has been a licensed hypnotechnician for five months. He is licensed to practice therapeutic hypnosis only by medical referral. In order to become licensed, a trained hypnotist must have, in addition to his formal training, verification from two medical doctors of their intent to prescribe his services

Tarpon Bay Village

SEAFOOD MARKET

MARINA SHELL SHOP

- Live Bait, Ice, Fuel
- Tackle Shop
- Boat & Tackle Rentals
- Canoe Rentals
- Evinrude Sales & Service
- Wet & Dry Boat Storage

- Fresh Local Seafood
- Stone Crab Claws
- Lobster
- Shrimp
- Cooked Orders To Go
- Gourmet hors d'oeuvres

- Largest On Sanibel
- Local Shells
- Imported Shells
- Unusual Gifts
- Shell Jewelry
- Mailing Service

CANOE TRAIL

-GUIDED SHELLING TOURS-GUIDED FISHING
BAY END OF TARPON BAY ROAD (813) 472-1323

TAKE OUT MENU

"Home of Fresh Seafood"

Seafood Platter

Fried Fish, Fried Shrimp, Fried Oysters,
Fried Scallops and Deviled Crab
French Fries, Cole Slaw, Hushpuppies

\$4.95

For (2) \$8.50 For (4) \$15.95 For (6) \$24.50

Fish Chowder

Dinners \$1.20 qt. Sandwiches

Fried Fish \$2.95	Fried Fish \$1.45
Fried Shrimp 3.50	Fried Shrimp 1.95
Fried Scallop 3.50	Fried Scallop 1.95
Fried Oyster 3.00	Fried Oyster 1.95
Fried Clam 2.95	Fried Clam 1.95
Fried Frog Legs	... 3.50		
Stone Crab 3.95		

Side Orders

French Fries \$.65
Cole Slaw \$.50. \$.95 pt.
Hushpuppies (serving of 6) \$.50

Appetizers

Shrimp Cocktail \$2.95
Crabmeat Cocktail 2.95
Clams on 1/2 Shell 1/2 doz.	.. 2.00
Oysters on 1/2 Shell 1/2 doz.	.. 2.00

NEW ENGLAND \$1.25 pt.
CLAM CHOWDER \$2.50 qt.

OPEN 11 AM - 8 PM 7 Days Weekly Phone 472-3196

Mid-Island
Real Estate



Phone (813) 472-1559
Corner of Wulfert & Sanibel Captiva Roads
5301 Sanibel - Captiva Road

- Frame home, 2 bedrooms, 1 bath Sanibel Center **\$52,500.**
- Gulf Drive lot, 400 ft. from beach **\$32,000.**
- Sanibel Bayous lots, well located **under \$15,000.**
- Cardinal Ridge, 1.2 acres, good vegetation, gulf access, has water hookup **\$27,500.**
- Chateaux-sur-Mer frame home, architect designed, near beach, full acre **\$175,000.**
- Gulf front lot, acre plus, single family, good vegetation, has water hookup **\$150,000.**
- Canal lot with dock, deep water access to Gulf and Sound, secluded **\$35,000.**
- Del Sega large lot on Bayou, secluded **\$45,000.**
- Chateaux-sur-Mer luxury home, 4 bedrooms, 3 baths, maid's quarters, large pool, acre lot, near beach access **\$275,000.**
- East Rocks lot, beautiful lagoon view **\$33,500.**

ROY E. BAZIRE

REGISTERED REAL ESTATE BROKER
ASSOCIATES: E. G. Konrad, Eva Pearl Cook

... the latest addition to police science

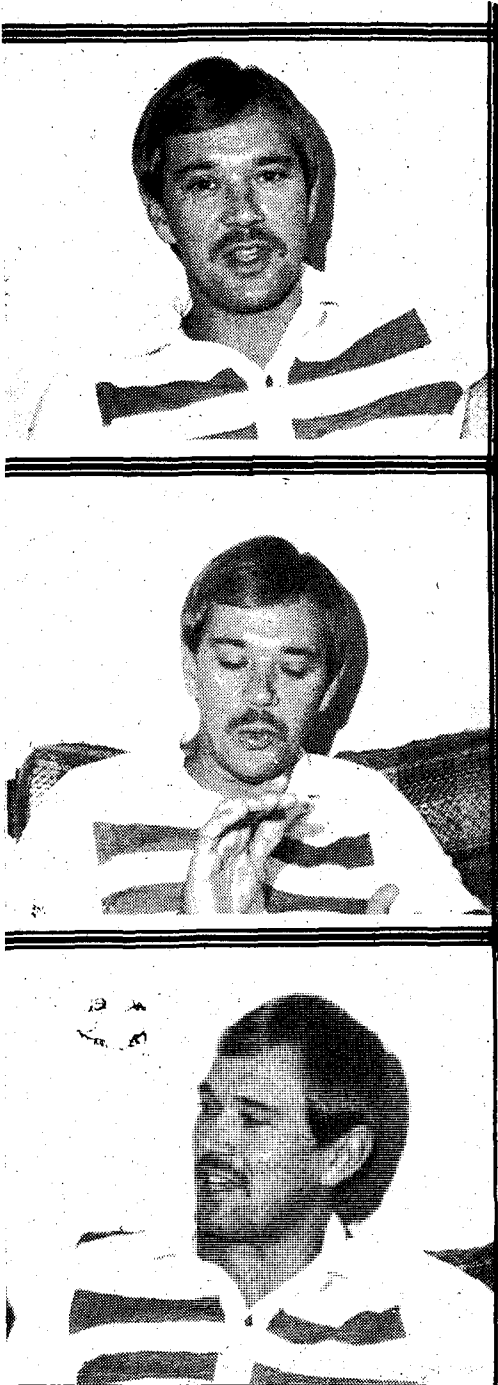

Lewis Phillips is an enthusiastic advocate of hypnosis in both his private and personal lives.

for therapeutic reasons.

"Therapeutic hypnosis can be used for dieting, sometimes smoking, phobias, sexual disfunctions, certain skin problems, asthma, migraine headache, depression," explained Densky. He also explained the value of hypnosis in non-therapeutic situations, such as an aid in sports efforts, educational study habits and just for relaxation.

There are several misconceptions about the so-called hypnotized state, and Densky was quick to alleviate my concern about these misconceptions.

"Hypnosis is not sleep," he reminded me. "It's exactly the opposite. You're more keenly aware during hypnosis. You don't give up your will to the hypnotist. You're always conscious and will accept only acceptable suggestions. It's a medium of communication with the sub-conscious mind ... a method of treatment."

Densky has good results helping people to lose weight through hypnosis. "The key to success," he added, "is self-hypnosis. It takes four sessions to learn and at the end of four sessions they're an expert at hypnotizing themselves. This makes them independent of me and also means that once they've lost their weight, they can keep it off. That's the key to their success. The ability is in them, not in me. It's not in the hypnotist. The hypnotist doesn't have any power ... doesn't have any magic."

One question that concerns most people is: Can I be hypnotized? Densky explains that everyone is hypnotizable, but not everyone can be hypnotized. An individual may resist for any number of reasons, and then hypnosis will not be possible. You can't hypnotize anybody against their will, but you can hypnotize people without their knowing it, he said. Densky added

that he might use the conventional pendulum approach to hypnotize a subject. I haven't ever used it, but if someone expected to be hypnotized that way, it might help.

Phillips, Hogan and Densky all expressed the need for good communication between the hypnotist and his subject. Trust was the word used by Phillips and Hogan; Densky preferred rapport. The intent is the same. There must be a desire to be hypnotized and good faith between the two persons involved.

There doesn't seem to be any indication that women make better subjects than men, or vice versa. Teenagers, as a whole, are the best subjects according to Densky. "I've also got sixty year old subjects that can go as deep as anybody, but teenagers are more suggestible. Their minds are open." Densky feels that children can be difficult subjects. "You can generally hypnotize them down to an age of six ... four if they're really precocious ... but you have to be really careful about the way you hypnotize them because they don't understand words. They don't know the word 'relax'. They don't know what a lot of words mean. You have to talk in their language. You have to speak in words that they understand. Hypnosis is based on experimental background ... what you've already experienced. I had somebody come to me and ask me to hypnotize a three year old for surgery. I said it couldn't be done ... a three year old can't concentrate and he's not going to understand most of the words you're saying and he hasn't got any experimental background. If you tell him 'You're getting cool and numb' ... he doesn't have the slightest idea of what you're talking about and it won't

work."

Densky added that a person does have to have some ability to concentrate to be hypnotized. "That means an I.Q. of at least 70," he said.

Densky conceded that hypnosis does not always work.

You can always hypnotize someone, but you can't always get the desired results. But of course, you can't always get the desired results from psychoanalysis or from medicine either. But most of the time ... like 90 percent ... it does the job. If it doesn't, it's probably because the person is very negative about it and has an I'll believe it when I see it attitude. It's not the method of treatment for everybody, he concluded.

Dr. Hogan referred again to the use of hypnosis in police work. It's no ego trip, he said. Maybe at first ... when you first learn to use it and see the results. But after a while ... after you've had more experience ... it balances out. Hogan indicated that a subject under hypnosis will not necessarily provide additional clues and may report inaccurately, again making it absolutely necessary to substantiate anything revealed with additional findings.

Chief Butler believes thoroughly in the new police investigative aid. There's no doubt, he said, that a person under hypnosis in an effort to aid in an investigation, is really trying to cooperate and come up with something. Under hypnosis, they can give us an advantage of a lot more insight into a happening and better recall of events.

Through the science of hypnosis, the Sanibel Police Department now has the ability to get a better look at circumstances surrounding a crime.

195 feet

Approximately ¼ acre Tract. Densely wooded. Has private walkway to Gulf right across the road.

\$32,500.00 Terms.

SURF REALTY, Realtor
470 Surf Sound Ct.
472-5200
472-4886

90 feet

85 feet

ACTUAL SURVEY

146 feet

101 feet Gulf Drive

WEST GULF DRIVE

239 feet

Rabbit Road

SANIBEL GROC SHOP

Liquors • Beer • Wine • Mixes

SALE GOOD
FRIDAY • SATURDAY • SUNDAY
JULY 28, 29, 30

 Stillbrook Bourbon  Old Thompson Blend  Walkers Canadian  Hudson Bay Scotch  Walkers Gin Tvarski Vodka Ron Mathusa Rum Kahlua Liqueur Old Milwaukee	Qt. 4.99 Qt. 4.79 Qt. 5.29 Qt. 5.49 Qt. 4.99 Qt. 4.49 Qt. 4.49 ½ Pt. 3.89 Case 24 Cans 5.79
--	--

PLUS MANY UNADVERTISED SPECIALS!!

OPEN EVERY DAY

10% DISCOUNT ON CASE ORDERS (Excluding Specials)

472-1682

Mon.-Thurs. 9:00 to 7:00 p.m.
 Fri.-Sat. 9:00 to 8:00 p.m.
 Sun. 12 noon to 6:00 p.m.

ISLAND SHOPPING CENTER (Next to Bailey's)

The Bank of the Islands gave a combination going away party for Eloise Brown, and Birthday party for Jim Lowman and Cathy Snyder last Saturday at the Coconut Grove. Eloise Brown is retiring from the Bank so she can have more time to do the things she wants to. (L-R Jim Hermes, Eloise Brown, Mr. Haynie, standing Jim Lowman and Cathy Snyder.)



PICK-A-GIFT FOR THRIFT

Effective July 3rd



choose your own

FREE GIFT

When you invest in a Palmetto Federal one to eight year term Savings Certificate

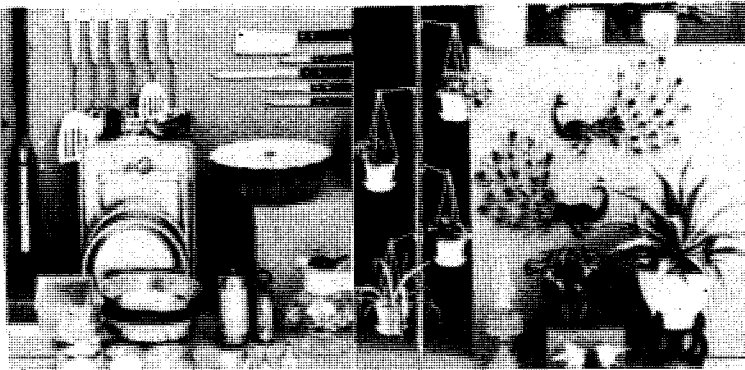

Choose From A Selection Of **60 GIFTS**

For a certificate deposit of \$1,000 to \$4,000, you may select from a handsome group of sixty gifts. Your gift will be delivered directly to your door.

GROUP A

Choose From A Selection of **40 GIFTS**

With a certificate deposit of \$5,000 or more, you may make your gift selection from a fabulous collection of forty gifts. Beautiful items, both useful and decorative.

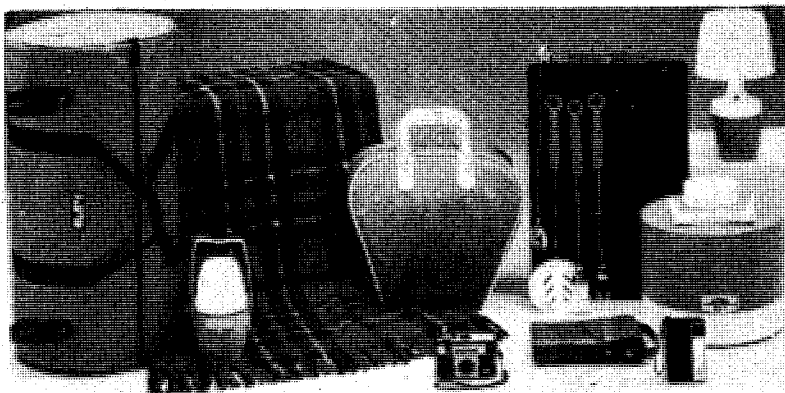

GROUP B

This is a limited offering and limited to the certificate plans listed below. One gift per family, please.

Five High Yield Plans To Choose From

8 YEARS SIX YEARS FOUR YEARS 30 MONTHS ONE YEAR
8% 7³/₄% 7¹/₂% 6³/₄% 6¹/₂%

\$1,000 minimum on all above certificates. Interest is compounded or paid quarterly. Check-A-Month available on balances of \$5,000 or more. Federal regulations impose a substantial penalty for early withdrawal.



Palmetto Federal Savings and Loan Association



8800 South Tamiami Trail
 939-0221

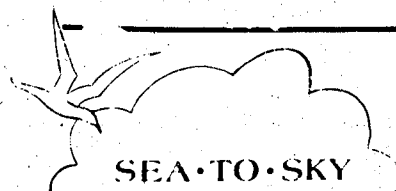

Royal Doulton Kaisar Porcelain Limited Jewelry
 Antique Ivory Figuriens Shell Handbags
 And many, many more unusual items
 for the discriminating taste
 in gift giving
 Periwinkle Place Shopping Center
 Doreen and Bob Slifor 472-1783

15% OFF

On Cleaner Carpets, Furniture, Drapes

Now is a great time to call Steamatic, the world's most professional cleaning service, to clean your carpets, draperies and furniture — at a 15% savings. Carpets cleaned by Steamatic not only look cleaner, they stay cleaner because they are cleaner. And our exclusive on-location dry-cleaning process can give your upholstered furniture and your draperies that "bright as new" look again. (And your draperies are cleaned without even taking them down.)

CALL FOR FREE IN-HOME ESTIMATE



PHONE 283-0988
 PHONE 334-3116

SAY HELLO TO THE GOOD GUYS AT SUNSET AUTO BROKERS

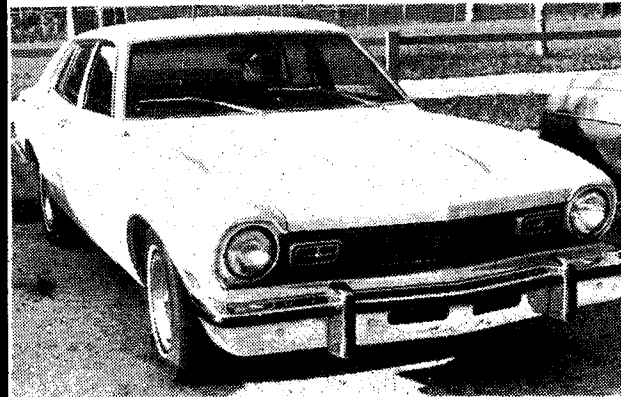

'74 MAVERICK, 4 DOOR, POWER STEERING, POWER BRAKES, AIR CONDITIONING, RADIO. \$1575.

— TRANSPORTATION CARS —

1972 CHEVY IMPALA 4 DR. \$595.00
 1969 CHEVY MALIBU 4 DR. \$595.00
 1965 BUICK ELECTRA 2 DR. \$675.00
 1975 PINTO WAGON V6, P.S., P.B., AIR, AM FM TAPE \$2295.00

SUNSET AUTO BROKERS

ON MCGREGOR BETWEEN COLLEGE PARKWAY & CYPRESS LAKE DR.

481-8800

481-8800

island lifestyles

by kay pratt

Postmaster

There used to be a fun game called post office. We doubt if kids play it any more. Why waste time with silly games when TV programs are so much more exciting ...

Paul Adams, who was transferred from the Lakeland, Fla. Post Office to Sanibel in December, 1972, does not find playing post office exactly a silly game. He has been dedicated to this profession ever since he resigned from the Navy as a very young man of twenty. He had already served three years on the high seas at that tender age, but he decided then and there what he wanted to do and be. He proceeded on a direct course and has had a long and successful career in his chosen field ever since.

Born in New Orleans, La., one of 11 children and son of a nomadic newspaper man, Paul had a catch-as-catch-can education. His father kept moving the family from place to place.

Soon after his short military career came to an end, Paul married Fae South from Shiloh, Tenn., who had recently won a Beauty Contest in 1949 and was acclaimed Miss Shiloh National Park Queen. Not a Miss America contest to be sure, but significant. Fae might have gone on

and pursued a glamorous life, but she also knew what she wanted to do and be. Her ambition was a natural desire to become a dedicated earth mother and Fae has found her career entirely fulfilling.

Their son, Kenneth Paul, had six years in the Navy as a Nuclear Power Operator and was recently married. He resides in Lakeland and so does their first daughter, Julie Fae, living with her husband and working as an executive secretary with the Alpha Engineering Company. Fae and Paul's

youngest daughter, Sheila Janice, now seventeen, lives with her parents. She has been the recipient of an Achievement Award and her name will appear in Rand McNally's Who's Who Among American High School Students this coming year.

Paul entered the Postal Service in July, 1951, as a substitute clerk, in Memphis, Tenn. He was transferred to Lakeland in 1960 in the position of Personnel Director of the large Central Florida area. Subsequently, his responsibilities were transferred to

Tampa and the P. O. Department sent him to the University of Oklahoma two different times, 1970 and 1971, to further his education by taking concentrated training courses in Management.

In 1972, Paul took another course in Modern Management Practices at the University of South Florida in Tampa, and during these years he traveled through Georgia, North Carolina, and Florida teaching compact one-week courses and symposiums in the field of

cont. on page 18

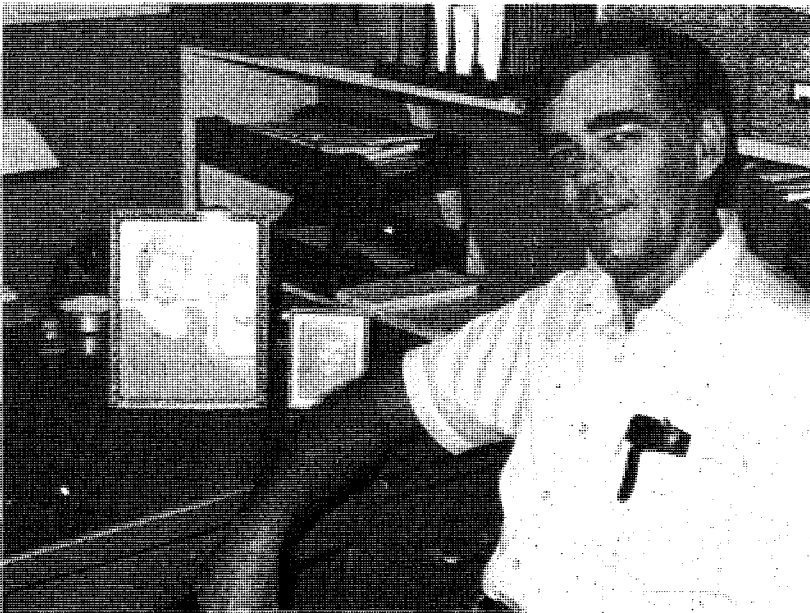

WOODY'S HEALTH FOODS
 natural frozen yogurt
 Mon.-Sat. 10-5 472-3666
 1640 Periwinkle Way
 Sanibel Island

DINING!
 5:00 TO 9:30 DAILY

Monfort of Colorado
 Aged Beef
 Scratch Fresh Seafood
 Cocktails

Served in a warm, friendly atmosphere

scotty's pub
 a family restaurant

1223 Periwinkle Way • Sanibel Island, Florida 33957 • Phone: (813) 472-1771

THE LADE BUTTERFLY INC.

Exotic Jewelry
 Decorative Accessories
 472-1387 Unique Gifts
 1711 Periwinkle Way next to Dotti's
 Sanibel Center Building

Health and Happiness, Inc. presents

FRESH ORANGE JUICE
 Glass or Quart

SOFT FROZEN YOGURT
 Cups, Cones, Sundae's,
 Shakes
 and Toppings Galore

Introducing
 H & H's 60° Hot Dog

Island Shopping Center
 (Next to Bailey's)

TOP O' MAST II
 Restaurant & Lounge

FOE'SLE LOUNGE
 OPEN FOR BREAKFAST, LUNCH & DINNER
 "Home of the Hot Popover"

SEAFOOD SPECIALTIES
 & Delicious Adventures
 for the Landlubber

1231 Tulipa Way next to Ramada Inn
 Sanibel Island
 472-3275

Sanibel's Newest — Serving the Finest

The Stoned Crab
 Seafood — Raw Bar

Featuring:

Long Island Raw Oysters
 Steamed Clams
 Fresh Seafood
 Beer — Wines

5:00 to 10:00 Daily
 Closed Wednesday

Daily Luncheon Specials
 11:30 to 2:30

Joan and Bill — Your Hosts
 708 Tarpon Bay Rd. 472-4809

F&B OYSTER CO.

A FISH HOUSE

2163 Periwinkle Way, Sanibel
 DESTINED TO BE ONE OF THE FINEST
 FISH HOUSES IN SOUTHWEST FLORIDA
 TRY OUR FAMOUS SHORE DINNER
 SERVED DAILY 5:00 TO 9:30
 BEERS AND WINES
 Phone 472-5276

RAW OYSTER BAR

island lifestyles

from page 17

Effective Postal Supervision. In other words, the education of future Postmasters.

After this background, being transferred to Sanibel may have seemed pretty small potatoes, but Paul loved it from the beginning. (Small is so right. The staff is packed in there like the proverbial sardines). The Adams lived on the Island at Captain's Walk for three years but had to move to the mainland because of the increasing expenses. A postmaster's salary can be stretched just so far.

Having to move and face the commuting wasn't easy. Paul had quickly become an active member of the community. He enjoyed Kiwanis Club programs and joined the Pirate Playhouse group under Ruth and Philip Hunters' direction for four years. As the pressures of his job increased, he asked for minor parts but last year, right in the middle of rehearsals, Paul was asked to take over the leading male role of "Leo" in "Laff That Off". There isn't even time enough any more for a loyal Kiwanian to do justice to being one. Socializing has to be a

sometimes thing for our Postmaster these days.

The story of our post office, hub of a tiny universe, is one more dramatic evidence of the rate of growth that has taken place during the last few years. You will be hearing more about the comparison of the old and the new when the all-important move to bigger and better quarters takes place — hopefully in April, 1979, although no one is holding his breath until that time.

When Paul Adams started supervising in 1972 the post office revenue was \$82,000. In 1978 the revenue is projected to be \$350,000. The number of rural boxes has increased from 600 to 1,928, more than tripled by 451 percent. There are still only 358 lock boxes in the post office (P.O.) and there's been a waiting list to procure one for three years. The new P. O. will have approximately 1,400 lock boxes.

You'll seldom know a more friendly, cooperative group of fine people anywhere than our P. O. representatives. Paul says he found this atmosphere here when he came, and he has tried to preserve it. He calls himself a "glorified clerk with a title."

His duties include keeping the books, making general management decisions, fighting the good fight as far as the budget is concerned, and pitching in with the rest of the staff when needed for clerical work, sorting the mail, etc.

Lloyd Kylo, Bill Real, Tom Traucht and Bob Rinco say that "the boss" is a wonderful guy who somehow manages to remain quite unflappable even when the going gets really rough during holiday seasons. The rural carriers, Virginia Frederick, Mack Gillooly, John Curran, and Gale Rose, say the same thing. And Paul can't say enough nice things about his co-workers either. The office is run as a close family unit and each member of the staff is well known for services to the public way beyond the call of duty.

The Sanibel Post Office has received praise from the official Postal Survey Team that comes around for inspection from time to time. Members of that team have said that they have never come across such an outstanding performance done in such an efficient and friendly way under such crowded conditions.

If we seem very enthusiastic about the whole business and the men who run it, it's because we have reason to).

To some of us, the thought of Christmas on a hot July day is, quote, indecent, immoral, and fattening, unquote. Last year was Paul's sixth Christmas rush; a nightmare for all concerned. This year will be much better. Earlier delivery will be provided by having five routes instead of four for rural delivery and plans for a third front desk are being formalized.

"I like to serve people and I'm thankful to be a Christian," Paul said at the end of our interview. "These days my socializing is pretty well confined to being a Deacon of the McGregor Church of Christ on McGregor Blvd. where I teach Bible classes to adults and children. When there's time - I like to go fishing and do yard work."

Our Postmaster wishes to thank the public for their patience and understanding, especially at Christmas time.

We wish the Adams family could move back to Sanibel. They belong here.

463-6313 **SPLIT**
BEER & WINE

Mexican and American Food
11 A.M. - 10 P.M.

RAIL RESTAURANT
1550 SAN CARLOS BLVD. FORT MYERS BEACH, FLA.

Snug Harbor Seafood Restaurant and Shanty Lounge

NEW SUMMER HOURS

Dinner from 5 to 10 pm 7 days a week
featuring an array of Ocean Fresh Seafood

The Shanty Lounge Daily 5 to 12 pm
enjoy your favorite drink and our special view overlooking the Harbor. Boaters - Dock FREE while you dine!

Sunday Seafood Brunch 12 noon to 4 pm
Sunday Dinner Hours 4 to 10 pm.

ON THE WATER AT THE SWING BRIDGE
FORT MYERS BEACH **463-4343**

Coconut Grove restaurant & cocktail lounge

• Now in Our 20th Year of Serving Fine Foods •

A FULL MENU OF MEAT AND SEAFOOD DISHES

WE ARE ESPECIALLY PROUD OF OUR SEAFOOD DISHES

A Wide Variety of Local and Gourmet International Delicacies to Please Your Palate

We offer **Daily Luncheon Specials**, plus our super colossal **Soup and Salad Bar** for your mid-day enjoyment from 11:00 to 2:30

At Dinner-Time our **SALAD BAR** has the widest selection on the islands to compliment our **Delicious Dinner Specials**

Choose a fine wine from our extensive Wine List

Hors d'oeuvres, hot and cold, and cocktails from 4 to 6

Open 7 days a week 11 am - 10 pm
Island Shopping Center 472-1366

Visit the Colonel and **BRING A FRIEND**

3 PCS. CHICKEN
MASH POTATOES, GRAVY,
COLE SLAW, ROLL
\$2.29 VALUE

FREE DINNER BOX

Buy one box and get the second one FREE.

OFFER GOOD THRU 8/4/78 NO. SUBSTITUTIONS ONE COUPON PER CUSTOMER
AT THESE LEE & CHARLOTTE COUNTY LOCATIONS:

- *3452 Cleveland Ave., Ft. Myers
- *330 San Carlos Blvd., Ft. Myers Beach
- *N. U.S. 41, North Fort Myers
- *4336 Palm Beach Blvd., E. Fort Myers
- *N. U.S. 41 Port Charlotte

tempers rise as donax intersection plan adopted

In session at City Council on Tuesday, July 18, Streets and Roads Task Force member George Christensen suggested that the City Council was "doing the planning" during a discussion on the alternates for improvements on Donax street where it intersects Periwinkle.

While road improvements have been a high priority on Streets and Roads Task Force agendas since that group met for the first time on April 4, the recommendation on the Donax intersection from the six man team has been to "leave it alone."

In spite of that recommendation, which has not been formally delivered to City Council yet from the Planning Commission (the Streets and Roads Task Force official parent group), City Council decided to accept the first and more expensive of the two alternatives for the Donax intersection recommended by the City's engineering firm, Howard Needles Tammen and Bergendoff (HNTB).

At a cost of almost \$125,000, the Donax Street intersection will be re-

aligned at a 90 degree angle and provided with a separate right turn lane. The existing bike path will be rerouted and some Australian pines will be improved to improve sight lines at the intersection. The HNTB recommendation stated that this alternate is intended to improve not only the traffic flow at the intersection, but the safety as well, and also allows for an extension of Donax from Periwinkle north to the Dunes Sub-division. The HNTB recommendation also indicated that the more expensive alternate will reduce the adverse effects of headlights and noise on the Bailey residence, by moving the intersection away from a direct line with the home.

This point brought Streets and Roads Task Force member George Christensen to his feet. "I've got a road by my house," he objected. "I'd like to have it moved." Mr. Christensen was concerned that, since Mr. Bailey is deeding the necessary right of way for the new Donax alignment to the City, and since according to a state statute,

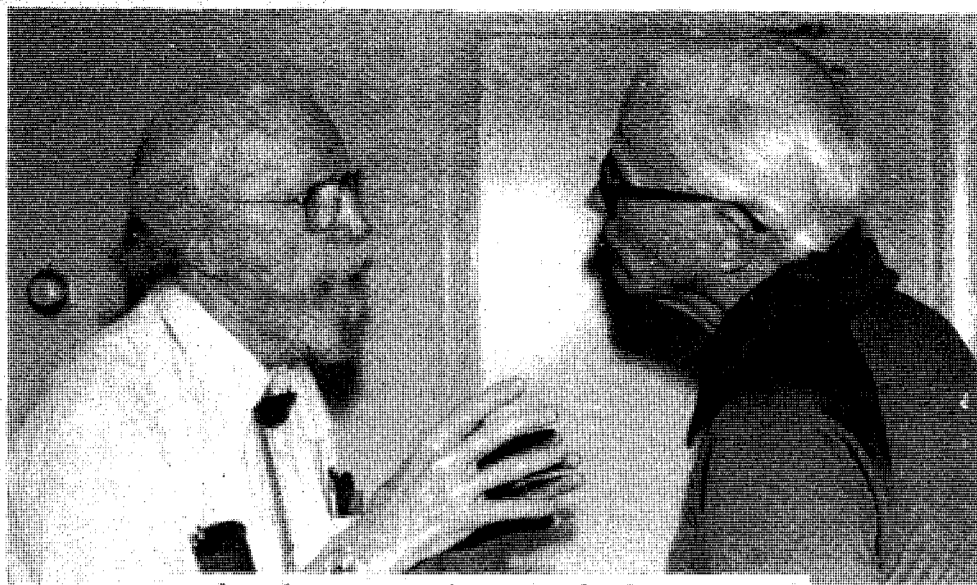

arthur hunter and francis bailey at odds over the donax st. intersection

he will be deeded the old right of way as the adjacent property owner, the HNTB recommendation placed too much consideration for the Bailey residence in its recommendation for alternate one on the Donax realignment.

Mayor Butler assured Mr. Christensen that it was only a small part of the consideration.

Alternate two for Donax would not be as efficient, according to HNTB, because the angle of the intersection is less than 90 degrees, and the alignment does not alleviate the headlight and noise problem for Mr. Bailey.

In other action on Tuesday, Council

appointed Frank Vellake as the architect for the preparation of the plans and specifications for the public rest rooms on the Island.

Council also voted to grant the City Manager the right to enter into contract with the Ashland-Warren Company as low bidders for the resurfacing of streets in the Rocks and Tradewinds Subdivisions and along West Gulf Drive, between Rabbit Road and the western end of West Gulf Drive. Tabulated cost for that project was almost \$17,000 less than the original engineering estimate, with a low bid by Ashland-Warren of \$82,929 for the resurfacing project.

CHOPPIN BLOCK
OPEN PIT
HICKORY SMOKED
BAR-B-QUE

SERVING DAILY FROM 11:30

HICKORY SMOKED
PORK • RIBS • BEEF • HAM
ALSO
FRIED SHRIMP & STUFFED SHRIMP

NEXT TO THE WOODEN BRIDGE
FORT MYERS BEACH

TAKE OUTS 463-9127

NOW OPEN
THE PIT LOUNGE

ADJACENT TO THE
CHOPPIN BLOCK
From 11 a.m. Seven days
— FEATURING —
ANDY WINKLER'S
ORANGE RIVER BAND
APPEARING TUESDAY THRU SUNDAY
DISAPPEARING MONDAY

the
"Letizias"
Continental Cuisine

*Specializing in
Northern Italian-French Dishes
Overlooking the Gulf
on Beautiful Sanibel Island*

SOMETHING LITE and DELICATE FOR EARLY DINERS
your choice

- **AUBERGINE ROUTINE**
(Eggplant stuffed with a variety of cheeses, spices and herbs.)
- **BAKED BREAST OF CHICKEN PARMIGIANA**
(With homemade sauce and delicate cheeses.)

your choice of entree on the Early Diners Special includes ...

● ANTIPASTO SALAD • ENTREE • PASTA • BREAD & BUTTER • BEVERAGE • DESSERT
ALL FOR ONLY \$4.95

Served 5:00-6:30 Mon. thru Fri.

Your Hosts: Margie Ann and Louis Letizia

3313 West Gulf Drive, Sanibel, Florida Open 5-9:30 Daily
472-2177 Closed Sundays
Sorry, no reservations

**Beach
Oyster
Bar**

NIGHTLY SPECIALS
All you can eat \$4.50
INCLUDES BEVERAGE

Monday
SPAGHETTI
WITH OUR HOMEMADE SAUCE

Tuesday
FRIED CHICKEN

Wednesday
FRIED CLAMS

Thursday
STEAMED ROCK SHRIMP

Friday
FRIED PERCH

Saturday
BBQ RIBS

Sunday
POT ROAST

CATCH OF THE DAY & FINE STEAKS
EVERYDAY

LUNCH FROM 11:00
HAPPY HOUR 4-6

DINNER FROM 4:00
DRINKS HALF PRICE

Featuring fine Seafood & Steaks with delicious Cocktails and a Soup & Salad Bar

Casual dining Serving Lunch everyday from 11:00 and Dinner from 4:00-11:00

SO. END FORT MYERS BEACH
VILLA SANTINI PLAZA
463-4933

Selected as one of:

BEST Restaurants FLORIDA

Harbor House

SANIBEL ISLANDS

First and Finest

SEAFOOD Restaurant

Dinner Hours
5:00 - 9:00

Lauded in:
New York Times — Miami Herald
Washington Magazine — Chicago Tribune
Chicago Sun Times — National Observer

Awarded Meritorious Food Service Commendation

1244 Periwinkle Way Closed Sunday 472-1242

Canada candidly by Lorraine Ashford

During these lazy, crazy days of summer, let me entertain you with the lighter side of the news. It came to my attention the other day that the City of Westmount, Quebec, (a suburb of Montreal.) is cutting off the Queen's maple syrup supply. Now, doesn't that make you want to reach for your first gin and tonic of the day?

The tax reforms in California have made waves as far as Westmount. It seems that when the Queen opened the Seaway back in 1959, the City of Westmount (in a very sweet gesture, I thought) made a gift of Quebec maple syrup to Buckingham Palace and the Queen, in perpetuity. That little gift

has cost the taxpayers of Westmount 500.00 a year.

In a recent effort, to cut back expenses the present City Council has decided that 19 years of perpetuity is enough and voted with a whopping majority to discontinue the gift. This local item was picked up by the media and took off! So much so that the harassed mayor Westmount was forced to call the Palace and explain.

The Westmount Council denies it, but it also shows that it is piqued that they never received a thank you note from the Queen or the Palace. So, the burning question is; does Her Majesty partake of maple syrup or is it given

out to the Palace staff? Heaven forbid is 19 years of maple syrup languishing in the storage shelves of Buckingham Palace for the future historians to ponder?

My personal belief is that the Queen doesn't touch the stuff. She belongs, no doubt to Weight Watchers for Anonymous Royalty. (Grace, of Monaco is a charter member.) I am sure, if she indulged in maple syrup, the thought would cross the Royal mind, "I wonder if we've thanked the colonies lately." On the other hand, given the ambivalent feelings towards the Crown to-day, especially in Quebec, a disgruntled postal worker could have sent the thank-you letter to the dead letter office in Buckingham, Quebec where it will lie dusty and unread til those future historians I mentioned get around to crossing the ocean.

Last time I saw Princess Margaret, I

believe its entirely possible that she is a closet maple syrup eater. Certainly the taxpayers of Westmount have a right to know where the syrup goes. I understand it is tagged in six languages! Maple syrup is now considered a gourmet food. Isn't THAT enough to poke a hole in your sap bucket! In Spring, the stuff flows like water from a tap but the locals can never buy it in its refined form. Small wonder if we're shipping it all over the world to ungrateful heads of state.

I have heard that during the French Revolution, Marie Antoinette told her subjects to eat cake. Now, the subjects are telling their Queen to eat pancakes—DRY!

I am sure the taxpayers of Westmount can put the 500.00 to very good use. I only hope the Queen does not storm over here shouting "Off with their heads!" But in Westmount, one of the last bastions in favour of the Monarchy, the City Council would probably volunteer their heads for the block. All for maple syrup.

Paid Political Advertisement

DEMOCRAT ROBERT L. SHEVIN FOR GOVERNOR OF FLORIDA

****Bob Shevin** is a good friend of Sanibel and Captiva. When the developers were destroying Sanibel's unique fresh water system, Bob Shevin's office in a first-of-its-kind cooperative effort with two other state agencies and local groups, stopped them. It was bold and courageous act — more so since environmental controls then were virtually non-existent.

****Bob Shevin** alone voted "NO" when the Governor and Cabinet were asked to sidestep the DRI process to cater to the desires of the Baker Baker Phosphate Corp.

****Bob Shevin** alone voted "NO" when the Governor and Cabinet were asked to approve construction of the environmentally destructive Dame Point Bridge in Jacksonville.

MARY STONEMAN DOUGLAS, author of "Everglades — River of Grass" will speak for Bob Shevin at a meeting August 12th on Sanibel. Time and place to be announced later.

Fill our coupon below to express your support of Bob Shevin for Governor.

.....
I will support Bob Shevin for Governor of Florida.

..... I will contribute to Bob Shevin's campaign. Please call on me.

..... I would like more information about Bob Shevin's campaign.

..... I would like to attend the Shevin for Governor meeting on Sanibel August 12th to hear Mrs. Douglas.

Name: _____

Address: _____

Fill in, clip out, and mail to Roy E. Bazire, P.O. Box 152, Sanibel, 33957.

This ad paid for by Roy E. Bazire, founder of Sanibel-Captiva Democratic Club and member of state Conservationists for Shevin Committee (*), and reported to Robert L. Shevin Campaign Fund.

(*) — Other state committee members include Dick Tillis, Chairman, Hal Scott, Marjorie Carr, Marjory Stoneman Douglas, Art Marshall, Shirley Taylor, Skip Livingston, David Anthony, Alice Wainwright, Joel Kuperberg, David and Casey Gluckman, Jeanne McElmurray, Dade Thornton, Dora Lee Russell, Frank Kapps, James Phillips, Paul Coley, Vickie Lynn Johnson, Ralph Johnson, Maggie Hurchall, Ted Sperling, Mike Simonhoff.

Paid Political Advertisement

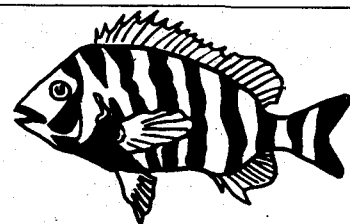

When you want to look your very best...
Renee's
House of Beauty

**HOT WEATHER
SPECIAL!**
OUR FAMOUS
WASH 'N WEAR PERM
NO FUSS — NO WORRY
\$20.00 COMPLETE
EXPERT MEN'S STYLING

STYLISTS —

CATHY BARKER • DARLENE DESIRANT • CATHY METCALF

Appointments not always Necessary.

Miner's Plaza So. McGregor Blvd. 481-1070
at the Beach Cut-off



Opening
Soon!

3 LIME TREE CENTER
across from Bank of
the Islands

**Tops
&
Bottoms**

**His & Hers
Jeans
&
Shirts**

Preston & Sally Woodring

municipal records

Atrium Fact Finding - The Fact-Finding committee will continue to meet in an effort to discover alternative remedies. The offer by Surety Construction Company to pay the \$15,000 cost of reconstructing the survey markers was not acceptable, nor was the offer to move the pool or the drainage field. The recommendation by the Fact-Finding Committee to the City Council was that the committee should continue to meet to consider other alternatives. Mayor Zee Butler abstained from voting on the Atrium issue, and Duane White also abstained. White said he had just discovered his business holds several notes from Atrium residents presenting him with a conflict of interests.

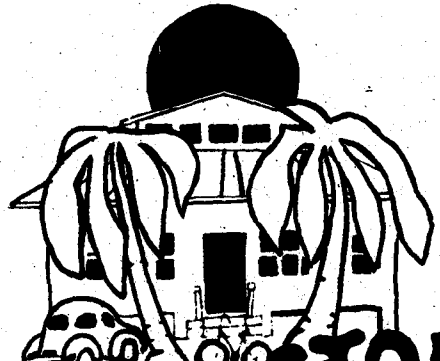

ISLAND STORE
CAPTIVA ISLAND

Mon.-Sat. 9 AM to 6 PM 472-2374
Captiva Road & Andy Rosse Lane

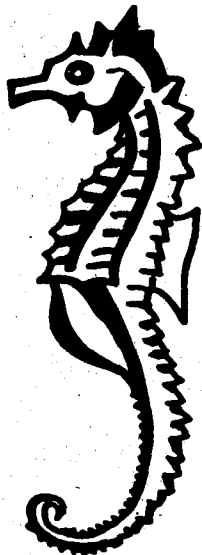

Castaways Resort and Restaurant

Located at Blind Pass
"Sanibel's Finest Shelling"

Beautiful Air Conditioned Rooms
Overlooking the Gulf of Mexico
— Color Televisions —
Best View of Sanibel's Spectacular Sunsets

Reservations
472-1212

Restaurant Closed
for Remodeling

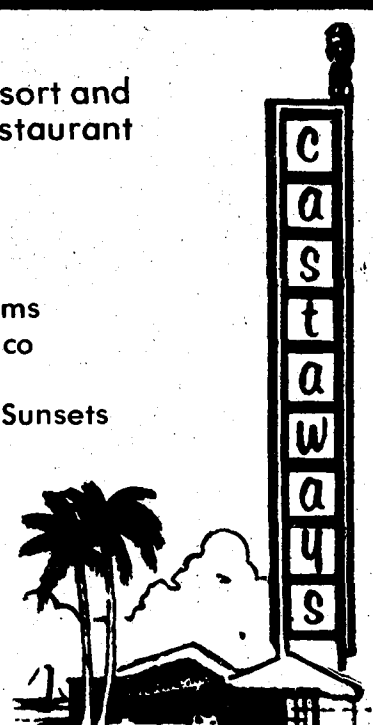

BankAmericard - American Express - Mastercharge

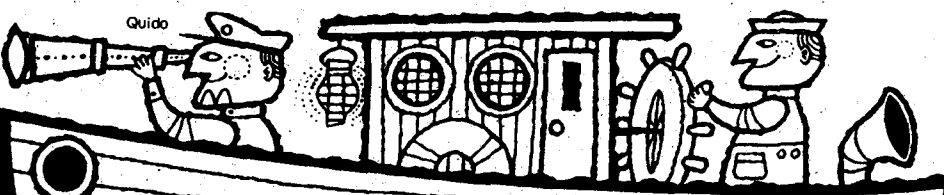

Sanibel Marina, Inc.

472-2723 Monitor CB Channel 13

Charter Fishing — Shelling — Sight Seeing — Sailing
Capt. Russ Mattson, Capt. Ted Cole, Capt. Charles Creagh,
Capt. Bill Gartrell

Lively Pin Fish and Shrimp — Tackle Headquarters for Sanibel
Cold Beer — Ramp and Dockage — Gas
Diesel — Pr-Mix
Sanibel's Only Deep Water Maring By Boat 1/2 Mile East of the Causeway

Periwinkle at N. Yachtsman Dr.

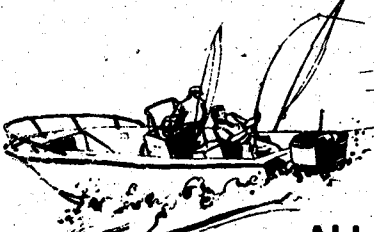

CHARTER FISHING — SIGHTSEEING

BY THE HOUR
HALF DAY OR FULL DAY

ALL EQUIPMENT FURNISHED
LICENSED GUIDE 472-1849

CAPT. HERB PURDY



1-813-936-1316

MAKE UP TO \$30,000.00
A YEAR RAISING
AFRICAN NIGHT
CRAWLERS

Commercial Earthworms

\$ WORMS \$

A Multi-million dollar business
can provide a good income at home.

BUSINESS OPPORTUNITIES

We will assist you in marketing your worm harvest. Growers needed urgently. To help supply our national worm demand. Hrs. Mon.-Sat. 8-7. Call 1-813-936-1316. FT. MYERS BRANCH OFFICE

If you don't believe in worms for profit, come to the farm & meet some happy worm selling owners. Or see our wall of proof!

BASS BAIT FARMS, INC.
3252 CLEVELAND AVE.

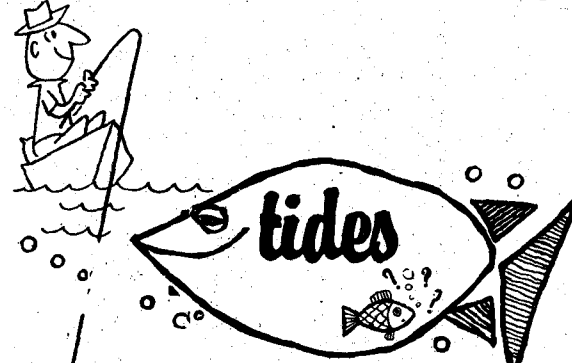

for
sanibel
and captiva
islands

Tu	25	*5:14 AM H	11:57 AM L	5:10 PM H	11:59 PM L
W	26	*5:57 AM H	1:21 PM L	6:34 PM H	
Th	27	12:35 AM L	*6:46 AM H	2:47 PM L	8:16 PM H
F	28	1:17 AM L	**7:39 AM H	4:06 PM L	10:04 PM H
Sa	29	2:09 AM L	**8:34 AM H	5:12 PM L	11:37 PM H
Su	30	3:08 AM L	**9:34 AM H	6:04 PM L	
M	31	12:29 AM H	4:11 AM L	**10:19 AM H	6:51 PM L
Tu	1	1:04 AM H	4:58 AM L	**11:04 AM H	7:31 PM L

* Denotes strong tides
** Denotes very strong tides

Tides courtesy of THE REAL EEL - Herb (Skip) Purdy

Conversion table: The above tides are for the lighthouse point of Sanibel only. To convert for Redfish Pass (north tip of Captiva), add 55 minutes to the time shown for every hi-tide, subtract two (2) minutes for every low tide. (NO, we don't know why, but it works. Instructions following are even less sense-sical but as we stated, they do work.)

For Captiva Island, Gulf side, subtract 30 minutes from each high tide, and subtract 1 hour and 16 minutes for each low tide.

For Captiva Island, Pine Island Sound (Bay) side, add 1 hour and four (4) minutes for each high tide, and add 52 minutes for each low tide.

In between these points on gulf or bay — guesstimate — and have good fishing, and or shelling.



CORALWOOD MALL, CAPE CORAL
4650 CLEVELAND AVE., FT. MYERS
ESTERO BLVD., FT. MYERS BEACH
935 PONDELLA ROAD, FT. MYERS
2232 GRAND AVE., FT. MYERS
LABELLE, COURT HOUSE SQUARE
U.S. 41 & STATE ROAD 78
WEAVER'S CORNER, N. FT. MYERS
4031 PALM BEACH BLVD., FT. MYERS
MINERS SHOPPING CENTER, FT. MYERS
1946 COLLEGE PARKWAY, FT. MYERS
WINN DIXIE PLAZA, IMMOKALEE

**SCHEDULED TERMINATION
DATE FOR DOUBLE
BINGO ODD, BINGO EVEN,
IS AUGUST 3, HOWEVER
GAME WILL END AS SOON
AS ALL TICKETS HAVE
BEEN DISTRIBUTED**

PLEASE REDEEM ALL PRIZES FROM
SERIES 18 BY SATURDAY, AUGUST 5

**ODDS CHART
AS OF JULY 14, 1978**

PRIZE VALUE	NO. OF PRIZES	ODDS FOR ONE STORE VISIT	ODDS FOR 3 STORE VISITS	ODDS FOR 6 STORE VISITS
\$2,002.00	11	193,182 TO 1	64,394 TO 1	32,197 TO 1
1,001.00	31	68,548 TO 1	22,849 TO 1	11,425 TO 1
200.00	56	37,946 TO 1	12,649 TO 1	6,324 TO 1
100.00	301	7,060 TO 1	2,353 TO 1	1,177 TO 1
20.00	697	3,049 TO 1	1,016 TO 1	508 TO 1
5.00	2,916	729 TO 1	243 TO 1	121 TO 1
2.00	9,747	218 TO 1	73 TO 1	36 TO 1
1.00	85,335	25 TO 1	8 TO 1	4 TO 1
TOTAL	99,094	21 TO 1	7 TO 1	3 1/2 TO 1

This game being played in the eighty-one (81) participating Winn-Dixie stores located in the following counties: Collier, Seminole, Osceola, Lake, Citrus, Brevard, Hendry, Orange, Volusia, Sumter, Charlotte, Lee and Marion.
Scheduled termination date: AUG. 3, 1978 or as long as ticket supply lasts.

Meat

W-D BRAND USDA CHOICE BONELESS
CHUCK ROAST
LB. **\$1.39**
SAVE 90¢

SWIFT PREMIUM OR FARMLAND
WHOLE PICNICS
3 LB. CAN **\$4.99**

W-D BRAND USDA CHOICE BONELESS
DELMONICO STEAKS
LB. **\$2.99**
SAVE \$1.10

USDA CHOICE HEART OF THE CHUCK
BONELESS CHUCK
HALF OR WHOLE
20 TO 28 LB. AVG. **\$1.29**
SAVE 50¢

W-D BRAND USDA CHOICE BONELESS CHUCK
CALIFORNIA ROAST
LB. **\$1.59**
SAVE 90¢

W-D BRAND USDA CHOICE BONELESS BOTTOM
ROUND ROAST
LB. **\$1.69**
SAVE 90¢

W-D BRAND USDA CHOICE BONELESS ROUND
RUMP ROAST
LB. **\$1.99**
SAVE 80¢

Dairy

SUPERBRAND ALL-NATURAL YOGURT
8-oz. CUP **29¢**

SUPERBRAND SOUR CREAM
16-oz. CUP **73¢**

CRACKIN' GOOD
CINNAMON ROLLS
9 1/2-oz. PKG. **59¢**

QUANTITY RIGHTS RESERVED
WINN-DIXIE STORES, INC.
COPYRIGHT—1978

PRICES GOOD JULY 27-29

SAVE 30¢
THRIFTY MAID SUGAR
Limit 1 with \$5.00 or more purchase excl. cigs.
5 LB. BAG **69¢**
ASTOR INSTANT Tea 3-oz. JAR \$1.59

EKCO ETERNA
Hand Decorated
STONEWARE
AUTUMN MEADOW & SOMERVILLE PATTERNS
FINAL OFFER
ONE WEEK TO COMPLETE SET
ALL FEATURE PIECES WITH EACH \$5.00 PURCHASE
Only **79¢**
ALL COMPLETE PIECES ON SALE PRICES AS MARKED.

Produce
HARVEST FRESH U.S. NO. 1
WHITE POTATOES
10 POUND VENT VU BAG **\$1.19**

HARVEST FRESH
PLUMS
2 LBS. **\$1.00**

HARVEST FRESH
NECTARINES
LB. **59¢**

HARVEST FRESH
PEACHES
LB. **49¢**

HARVEST FRESH
CHERRIES
LB. **99¢**

ARROW BLUE, WHITE, COLD WATER OR NO PHOSPHATE
DETERGENT 49-oz. BOX **79¢**

WESSON OIL
Limit 1 with \$5.00 or more purchase excluding cigarettes.
48-oz. BTL. **\$1.79**
WESSON Corn Muffin Mix 4 PKGS. 89¢

JUMBO LILAC ALL COLORS
PAPER TOWELS
3 ROLLS **\$1.09**
SAVE 39¢ ON 3
ARROW ASSORTED PAPER Napkins 2 PKGS. \$1.19

DEEP SOUTH MAYONNAISE
QT. JAR **69¢**
SAVE 40¢
DEEP SOUTH FRESH PAK SWEET CUCUMBER Chips 72-oz. JAR 69¢

THRIFTY MAID ALL VARIETIES
FRUIT DRINKS 2 46-oz. CANS **88¢**

SAVE 33¢ ON 4
VAN CAMP PORK & BEANS
16-oz. CANS **\$1.18**
Van Camp's Pork & Beans
THRIFTY MAID HOT DOG Chili 4 PKGS. \$1.00

SAVE 58¢ ON 8
THRIFTY MAID TOMATO SOUP
10 3/4-oz. CANS **\$1.18**
THRIFTY MAID Tomato Soup
CRACKIN' GOOD STACK PACK Saltines 1-LB. BOXES \$1.09

SAVE 40¢
SCHAEFER BEER
Limit two 6-pks. with \$5.00 or more purchase excl. cigs.
12-oz. CANS **\$1.19**
CRACKIN' GOOD REGULAR OR WAVY POTATO TWIN PACK Chips 8-oz. PKG. 79¢

Frozen Food

Superbrand SHERBET
2 HALF GAL. **\$1**
COUNTRY FRESH PRESTIGE ALL NATURAL Ice Cream HALF GAL. \$1.99

11-oz. JELLY, 9-oz. GLAZED, 14-oz. BOSTON CREME OR 9-oz. CHOCOLATE ICED
MORTON DONUTS
2 PKGS. **\$1.00**

DEEP SOUTH FRESH PAK
KOSHER DILLS 48-oz. JAR **99¢**

SAVE 38¢ ON 2
THRIFTY MAID BARTLETT PEARS
29-oz. CANS **\$1**
THRIFTY MAID Bartlett Pears
THRIFTY MAID WHOLE PURPLE Plums 2 30-oz. CANS \$1.00

SAVE 20¢
THRIFTY MAID SELF-RISING OR PLAIN FLOUR
5 LB. BAG **59¢**
THRIFTY MAID Shortening 3-LB. CAN \$1.49

SAVE 30¢
DIXIE HOME TEA BAGS
100-CT. PKG. **\$1.19**
DIXIE HOME Tea Bags
GOLDEN CROWN LEMON Juice 3-LB. SIZE 59¢

SUPERBRAND ICE CREAM BAR OR ICE CREAM SANDWICHES
12-PK. PKG. **\$1.19**
FEEZER QUEEN **ENTREES**
2-LB. PKG. **\$1.59**

food for thought

By JULIE GRAY
Food Editor

"You take the freshest and best pork that money can buy, and then you add the special seasonings that I add to it and you do all the necessary things to it. And if you know what you are doing, you have the best pork sausage in the world," says Armondo Leone.

Leone should know - he heads Leone Provision Co., 916 S. E. 14th Ave. in the industrial park.

Leone was born in the United States, but his family returned to their native Italy in 1929 because of the Depression. Home for the Leone family was Torino, Italy, near Milano and about 160 miles south of France.

"I've been cooking since I was eight years old," Leone said in his beautiful Italian accent.

"I started peeling onions and polishing pots while we still lived in Italy. You might say I was born into cooking."

"No one who doesn't like to cook can get the right flavorings and seasonings in their food," Armondo said.

"By the time I was 14 I was in Naples making pizza, and they were delicious." He spread his arms wide, as if he were tossing a pizza high in the air to stretch the dough.

By the age of 19, Leone was back in the U. S. and in the restaurant business in Newark, N. J. Shortly thereafter, when he was in his early 20's, he opened his first restaurant called GiGi's.

"I just love it, that's all. I really love to cook. I can't get away from it. It's a part of me," said Leone with a contented smile.

"My whole family loves to cook," he said. "Someone is always cooking at our house."

He for the Leone family is on Pelican Boulevard. They have been commuting there from their former New Jersey home for more than 10 years. Finally about a year ago for many reasons, not the least of which the beautiful weather, the Leones moved to Cape Coral as year-round residents.

Armondo met his vivacious wife Rosaria, from Naples, Italy, when she ordered pizza in his seaside New Jersey restaurant. Spotting pretty Rosaria, he decided to serve her

personally and romance followed. Other members of the Leone family are Armondo Jr., who will be 15, Lisa, 12, and Paula, 11.

Armandino and Lisa have indicated they want to go into the business too, Leone said.

"The other night Lisa made the whole dinner and it was delicious. They're always cooking. Already Armandino is bugging me to open up a restaurant for him."

"At home I even cook too," Leone said. "Rosaria cooks too, but she loves it when I cook."

Eight kinds of Italian sausages are made daily on the premises of the Leone Provision Co. "I know the need for quality Italian products down here. People want the good things and they have not been available or easily obtainable anywhere between Tampa and Miami," Leone said.

"I have quality. I love quality. You get what you pay for. I sell my sausages and other products to many of the hotels and restaurants around here.

"Many people in the trade know that our quality is the best. I feel that it is possible to have the best quality and still be competitive with price.

"When you go only for the price you so often lose the quality and you get junk."

A note hanging on the wall from one of Leone's restaurant customers reads, "The sausage is extra lean, comes fresh with personal delivery. The best sausage I have used as far as seasoning, and the lowest in fat content."

Leone said he often gets notes like these from other chefs, "who like to help a guy who is new in the business and has a good product."

Inside the Leone Provision Co., the immaculate sparkling cases contain a variety of mouthwatering products.

There are the eight varieties of Italian sausage, from breakfast to dietetic; low-fat veal sausage; several kinds of meatballs; eggplant rollatine; ravioli; manicotti; ziti and many kinds of imported and domestic Italian cheeses.

Leone Provision also carries a full line of tomato products, as well as real Italian "cold cuts" such as Pancella, Italian Salami Cotto, Zampino, Cotto Ghino, and Abruzzisi.

Leone is also starting to make German sausages such as Bratwurst, in response to customers' requests.

Rosaria serves the retail customer, who is always welcome to come and browse, sniff, savor and purchase. She also makes the meatballs and assists in all phases of this family endeavor.

When he's not making sausages and other things, Leone is out making deliveries to restaurant customers in the area.

Personal delivery and knowledge of the customer's needs are vital to the success of his business, Leone said.

SAUSAGE AND MUSHROOMS

Mild Italian Sausage (about 1 pound)
½ lb. mushrooms, chopped coarsely
a little bit of butter
2 oz. sherry wine

Flatten out the sausage and cook it. Take the mushrooms and saute them in the butter and maybe a little oil (olive oil). Add them to the pan with the sausage in it and cook together for a few minutes with sherry. Serve either in a toasted roll or on a plate.

SAUSAGES IN CREAM

1 pound sausage links cut in 1-inch pieces
¼ lb. fresh mushroom caps
2 tbsps. butter
½ cup dry white wine
3 tbsps. cream or nondairy "cream" product

Cook links and drain the fat. Set the sausage bits aside; in the same pan, saute the mushrooms in the butter. Let them cook until they begin to wilt. Add the wine and scrape up all the nice brown flavoring. Cook for a few minutes with the sausage and mushroom caps. Add cream, heat and serve. Good over toast or rice; great for a brunch.

DUGGERS OF SANIBEL

Unusual Ceramic & China Painted Gifts

2902 Gulf Drive 472-1181 Tuesday thru Saturday 10-3

BLIND PASS Cottages & Marina

On the west tip of Sanibel at Captiva Bridge
Tackle Shop, Boats, Motors, Live Bait,
Soft Drinks, Cold Beer and Ice

Call (813) 472-1020

Most rustproofing guarantees don't fully cover rust.

No one can completely guarantee their rustproofing. Except Ming. Want proof? Just check guarantees.

Most other guarantees are just "money-back" guarantees. MING covers all rust repairs, regardless of cost. • OTHER guarantees are limited to 50,000 miles. MING guarantees new cars for 5 full years, regardless of mileage. • • OTHER rustproofing guarantees cover your car only from the windows down. MING covers your entire car, top to bottom. • OTHER guarantees don't cover areas which are accidentally missed during application. MING guarantees every square inch of metal paneling on your car against rust from the inside out. Other guarantees are void if you sell your car. MING's valuable guarantee is fully transferable and can help you get more for your car if you sell it.

Phone or drive in to your Ming Auto Beauty Center right away. And get the only true rustproofing guarantee you can depend on.



THE FULL CIRCLE
OF AUTO PROTECTION
4248 FOWLER AT EAST MALL DR.
FORT MYERS, FLORIDA 33901
(813) 939-1440
OTHER FLORIDA LOCATIONS
NORTH MIAMI, FLORIDA 33162
305 944-1222
LAUDERHILL, FLORIDA 33313
305 587-6450

Foxworthy's
OVER 50 YEARS

Residential and Commercial
Designing and Furnishings
OPEN 10 TO 5 MONDAY THRU FRIDAY

No. 1 Periwinkle Pl.
SANIBEL
ISLAND
472-1327

1601 Jackson St.
DOWNTOWN
FORT MYERS
334-1348

the Unusual Deli

home of

Julie's Kitchen

where the good food starts

Dear friends,

Remember, we're the FRESH FOOD DELI

✓ Eat in or take out

*Freezers with quiches, crepes, hors d'oeuvres and dinners to go (Many other things too)

*Cheesecake... both our famous cheese cake with or without fruit topping and now CHOCOLATE CHEESECAKE with a devil's food crust. Mmmmm!

*Baklava and other treats from our revolving pastry case.

*Salt free and additive free food almost always available.

*Unusual and hard to find pastry and cooking needs, such as Macaroon Paste, Puff paste dough, strudel dough, Kataifi dough, slivered almonds and walnuts in bulk. High gluten flour, Yeast and so many others.

*Got a special request? We'll try our best to help you!

Come on in and let's talk about your holiday and fall entertaining plans while you have a "famous deli" lunch or dinner.

WE'LL CATER

936-6003

YOUR PARTY!

5605 S. Tamiami Trail - Dragon Plaza



CALENDAR

activities

things to do

BINGO MUREX - American Legion Home, Thursday, 8:00 p.m. No minors. Sanibel - Captiva Road, 472-9979.

BIRD TOURS - Griffing Bancroft, 472-1447; George Weymouth, 472-1516; Dick Frieman, 472-1315.

FISHING GUIDS FOR CHARTER - Capt. Ted Cole, 472-2723; Capt. Doug Fischer, 472-1551; Capt. Baughn Holloway, 472-2802; Capt. Belton Johnson, 472-1122; Capt. Duke Sells, 472-1784; Capt. John Johnson, 472-1020; Capt. Bob Sabatino, 472-1784; Esperanza Woodring, 472-1126; Capt. Chic Kennedy, 472-4087; Capt. Herb Purdy, 472-1849; Capt. Jerry Way, 472-1784 or 472-1007; Capt. Butch Coltrill 472-2917

ELLIE MY'S MUSEUM - By appointment Call 472-2121.

NATIONAL HISTORY FIELD TRIPS - to Sanibel's wildlife habitats - For reservations, information, times and fees, call 472-2180. with naturalist. George Campbell

SAILING - (lessons and - or charter) - Southwind, 472-2531; Paul Taylor, 472-1551; Chic Kennedy, 472-4087; Mike Fuery, 'Twee' Waters, 472-1784; Ft. Myers Yacht Charters, Roger Noduff, 463-2320, Twin Palms Marina; Papa Nui, 332-1200; Off-Shore Sailing School, S.S.P., 472-1551, ext. 4141, Capt. Hugh Alexander, Island Boat Rentals, 472-2228.

SIGHTSEEING TOURS - Herb Purdy, 472-1849; Tarpon Bay Marina (canoes) 472-1323; Capt. Chic Kennedy, 472-4087; Capt. Herb Purdy, 472-1849; Mike 472-1784; Jerry Way, 472-1784; Capt. Hugh Alexander, Island Boat Rentals, 472-2228. Cap't. Al Rogers. Docked at Timmy's Nook. Call Operator WX5811.

TENNIS & SCUBA EQUIPMENT (RENTAL) - The Real Eel, 472-2674.

OFF ISLAND DAY TIME ATTRACTIONS - Edison Home in Fort Myers, 334-1280; Shell Factory, U.S. 41 North Fort Myers; Jungle Cruises, 334-7474, Fort Myers Yacht Basin; Waltzing Waters, 283-0636, Pine Island Road.

Macrame, Weaving, crewel, needlepoint, knitting, or crocheting lessons **IDLE HOURS**, 31 Periwinkle Place. By appointment only. 472-1039.

DUNES TENNIS RACQUET CLUB. Full racquet facilities. 472-3522.

THE SANIBEL-CAPTIVA CONSERVATION CENTER is now open from 9 - 5 daily except Sunday. Exhibits and nature trails. Members free. Nominal charge to visitors.

how to get there

BOATS (FISHING) TO RENT - Blind Pass Marina, 472-1020; Island Boat Rental, 472-2228; 'Tween Waters Marina, 472-1784; Tarpon Bay (canoes) 472-1323.

BOATS (Sail) TO RENT - Southwind, Inc. 472-2531, Island Boat Rentals, 472-2228, Capt. Hugh Alexander.

MOTORCYCLE RENTALS - Sanibel Motorcycle Rentals, 1203 Periwinkle - 472-2001.

BICYCLES FOR RENT - Hines Rental, 472-2847 or check the motel you are staying in.

CAPT AL'S ISLAND CHARGER SERVICE at Timmy's Nook, Captiva.

clubs & civic groups

AMERICAN LEGION POST NO. 123 - American Legion Home, second Tuesday of the month, 8:00 p.m.

SANIBEL COMMUNITY ASSOCIATION, INC. - Sanibel Community House, 1st Tuesdays, 6:30 p.m.

LADIES GUILD of the Sanibel Community Church meets at 1:30 every third Thursday of the month. For details phone 472-2425.

THE SANIBEL-CAPTIVA UNIT OF THE LEAGUE OF WOMEN VOTERS - meets at 10:00 a.m. on the second Monday of every month at the West Wind Inn. The public is warmly invited.

Sanibel-Cativa Kiwanis - Top O Mast II, Breakfast Meeting each Wednesday 7:30 A.M.

church

ST. ISABEL'S CATHOLIC CHURCH

Father Gerard Beaugard, Pastor

Sunday Mass 8:30 and 10:00
Saturday evening Mass 5:30 p.m.
Daily Mass 5:30 p.m.
Vigil Mass preceding Holy day 5:30 p.m.
Holy Day Mass 10:30 a.m. and 5:30 p.m.
Confessions: Before each Mass and at 3:30 p.m. Saturdays.

FIRST BAPTIST CHURCH

The Rev. Gerald Frost, Pastor

SUNDAY SERVICE:
Sunday School 10:00 a.m.
Worship 11:00 a.m.
Evening Services 7:00 p.m.
WEDNESDAY EVENING:
Prayer Meeting 7:00 p.m.

ST. MICHAEL'S AND ALL ANGELS EPISCOPAL CHURCH

The Rev. James D.B. Hubbs, Rector

SUNDAY:

Holy Communion 7:30 a.m.
1st & 3rd Sundays 9:30 a.m.
MORNING WORSHIP:
2nd & 4th Sundays 9:30 a.m.

SANIBEL COMMUNITY CHURCH

The Rev. Bruce E. Milligan, Pastor

Summer Sunday Worship Service 10:00 a.m.
Church School Classes will be held during the Worship Service.

CHRISTIAN SCIENCE SERVICES

Now being held at the Sanibel Library
Phone 472-4449

Sunday 11:00 a.m.

Wednesday 8:00 p.m.

TEMPLE BETHEL

Del Prado Parkway, Cape Coral
Rabbi Robbert Scott
542-6210

Friday Worship 8:00 p.m.

THE SHEPHERD OF THE ISLANDS LUTHERAN CHURCH

The Rev. Judson H. Westgate, Pastor
472-4249

Sanibel Community Association Building

Sunday Worship 9:00 a.m.
Sunday School 10:15 a.m.

CHAPEL BY THE SEA

Dr. David E. Weinland, Minister

Services 3rd Sunday, Nov. thru 3rd Sunday in April
Sunday Worship 10:00 a.m.

SANIBEL CONGREGATIONAL UNITED CHURCH OF CHRIST

Rev. Dr. James W. Lenhart, Minister
472-5290

Sunday Worship at
The Dunes Golf & Country Club Clubroom 10:00 a.m.

JEWISH COMMUNITY CENTER of Lee County

915 SE 47th Terrace, Cape Coral, Fla.
Rabbi: Samuel Silver, D.D.
549-1967

Saturday service 10:00 a.m.

GREEK ORTHODOX CHURCH

Cypress Lake Drive
The Rev. Fr. Arthur Kontinos
481-2099

Orthos 9:30 a.m.
Divine Liturgy 10:00 a.m.

*The Owl and
The Pussy Cat*

Summer Hours:
10 - 5

GIFTS
AND
ACCESSORIES

CAPTIVA, FLORIDA 33924
TEL.: 472-4974

Elsie Malone

"A SHELL COLLECTOR'S PARADISE"

Specimen Shells — Florida & Worldwide

P.O. BOX 54
SANIBEL ISLAND, FLA. 33957

2422 PERIWINKLE WAY
PHONE (813) 472-1121

Don't leave the Islands!
We'll get you
TV Picture Perfect
SERVICING ALL MAKES
Radio and Stereo Service

**SANTIVA
TV SERVICE, INC.**

472-4626 Behind Scotty's 1223 Periwinkle

**art fac
SANIBEL**

- Carmichael and LaTona Photographs
- Prints on artists' canvas
- Wood Carvings
- Batiks
- C...

Sanibel, Florida 33957
Phone (813) 472-3307

"Southwest Florida's only
airstep shoe store"

Women's
air step shoes

Final Markdowns

Final Days . . . ?????

Season end
Semi-annual **Sale**

**20% TO
55% OFF**

Haggerty's airstep/footworks
Dragon Plaza — 5605 S. Tamiami Tr.
Fort Myers — Daily 9:30-5:30
Visa — Mastercharge 936-7172

A warm, friendly welcome
awaits you at
FIRST BAPTIST CHURCH

All are invited to utilize our 24-hour non-denominational
Prayer Center whenever possible.

Sunday School (all ages) 10 a.m.
Morning Worship 11 a.m.
Evening Worship 7 p.m.
Wednesday Bible Study & Prayer 7 p.m.
Gerald Frost, Pastor Tel. 472-1018

**SANIBEL CONGREGATIONAL
UNITED CHURCH OF CHRIST**

Visiting Minister
Rev. Robert L. Burt

Cordially invites you to share in
the worship, work and witness of
the new church of our community.

**THE DUNES GOLF AND COUNTRY CLUB
— CLUB ROOM 10:30 A.M.**

Do Worship and Grow with us!
Our Church Office 1473 Periwinkle Way
472-5493 or Home 472-5290

community calendar

Lions Club

The Lions and guest attending the regular meeting of the Sanibel-Captiva Lions Club at the American Legion Hall were entertained and educated by Mr. Ed Underhill of the Unpressured Cooker.

Mr. Underhill demonstrated the capabilities and uses of the latest model of Food Processor, by slicing vegetables, making cole slaw, "ground bee," and mixing and a salad dressing. The dressing was used by the Lions at the meal that followed. The next meeting will be Aug. 2, 6:30 PM at the American Legion Hall.

American Cancer Society

July 26 will be the date of a telethon emanating from the TV 20 studio. Host will be Ken Nelson, newscaster, and Dana McCann, sportscaster both with that station. From 7 pm to 11 pm on that date a total of fifteen bands, singers and acts from top entertainment in southwest Florida will be featured. There will also be numerous films showing the local American Cancer Society in action and stories from area cancer victims telling how cancer has affected their lives and how the society is helping.

Kiwanis

Sgt. Trefny of the Sanibel Police Dept. was guest speaker at the last meeting of the local Kiwanis. He gave a most interesting and informative talk on the upcoming Police Olympics in California at which Sanibel will be represented by officers Noone, and Trefny in swimming events.

The KIWANIS two for one dinner tickets are still available.

American Business Women's Association

A reminder that an organizational lunch meeting of this group will be held July 26 at 1 pm at the Coconut Grove. Any and all interested in joining this fine group are cordially invited to attend. For further information please call 472-2946.

Voter Registration

Voter registration will be conducted at the County Park, Fort Myers Beach August 2, 10 am-1:30 pm and 2:30 pm - 6 pm.



Executive Services, Inc.

Sanibel's Complete Real Estate Company

OCEAN FRONT

Just listed! A 3rd floor, 2 bedroom, 2 bath unit fully furnished. The spectacular Gulf view and private, unspoiled beach make this apartment one of the best buys on the Island at \$89,500 furnished.

ONE OF TEN ON A CANAL

Newly listed after being occupied by owner only during the season. One of ten townhouses in the Seawind Condominium. Only 15 minutes to San Carlos Bay with no wake. Two bedrooms upstairs. Bath and one-half. Two balconies and a spacious screened terrace. A boat dock with every apartment. Nicely furnished. Priced for a quick sale at \$65,000.

RENTAL POTENTIAL

Rentals are at their best in this popular Island condominium. Add to that the spectacular view of the Gulf from this third floor, 2 bedroom, 2 bath apartment at Loggerhead Cay plus tennis, swimming, putting green and more. A prized package at \$110,000 including carpeting and drapes.

SO YOU WANT YOUR OWN SHOP INSTEAD OF RENTING?

We have listed 3.2 acres zoned restricted commercial. Several shops could be put on this superbly located property. Across from several established businesses with 350' frontage on Periwinkle. Probably the most significant restricted commercial piece of property on Sanibel. Terms negotiable. Call now on this property.

LAKEFRONT LOT

A brilliant artist is seldom appreciated in his time, but after he dies he becomes famous. Fortunately, the subdivision where this lake front lot is located hasn't died. It is alive and healthy with 6 new housing starts. Located mid-Island near Blind Pass. \$18,900.

TAKE OUT FOOD BUSINESS FOR SALE ON SANIBEL

An established food business located in one of Sanibel's major shopping plazas. Plenty of parking and established clientele. Potential for expansion. All equipment is brand new. Everything you need to run the business. Ideal for family. No blue sky at this price. It would cost you more to start a business from scratch.

Executive Services, Inc.

Registered Real Estate Broker

Main Office: 455 Periwinkle Way
(At the Lighthouse end of the Island)

472-4195

Branch Office: 2427 Periwinkle Way
(Just before Bailey's Shopping Center)

472-3133

OPEN 10:30 TO 5:00

Fine Irish Fashion

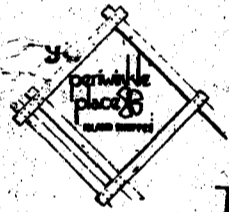

irish look

Traditional Knitwear

Galway Crystal

Meet Your Neighborhood Professional

J. (Bill) Munroe,
Realtor Associate
Lots and Acreage Specialist



A quarter of an acre, or a quarter of a Section (180 acres) Bill's expertise in land, zoning, restrictions, and potential growth patterns can help make your next investment more secure. If your future includes moving to the "country" on a mini-farm or a small hide-away, give Bill a call.

Century 21

Grable Realty, Inc.

939-2121

AND IN LEHIGH ACRES 369-1121

1752 Colonial Blvd., Ft. Myers 33907
EACH OFFICE INDEPENDENTLY OWNED

We have a home for you!

"the Brunswick"

3 Bedroom, 2 Bath with Screened Porch

- Cathedral ceiling in living room and screened porch
- Spacious family kitchen

The Brunswick is one of several homes under construction in the Dunes Subdivision. Buy now so that you can make personal selections. Or consider this design for your Sanibel lot.

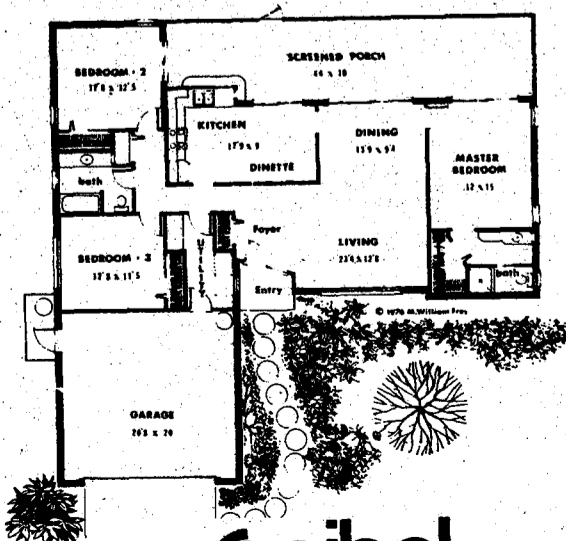

For Information Call
481-2512

sanibel
homes

This Junonia Shell was dug up by Sam Phillips, a vacationer from Maryland, on a West Gulf Drive beach this last week showing that there are still good shells on the beach if you look carefully.

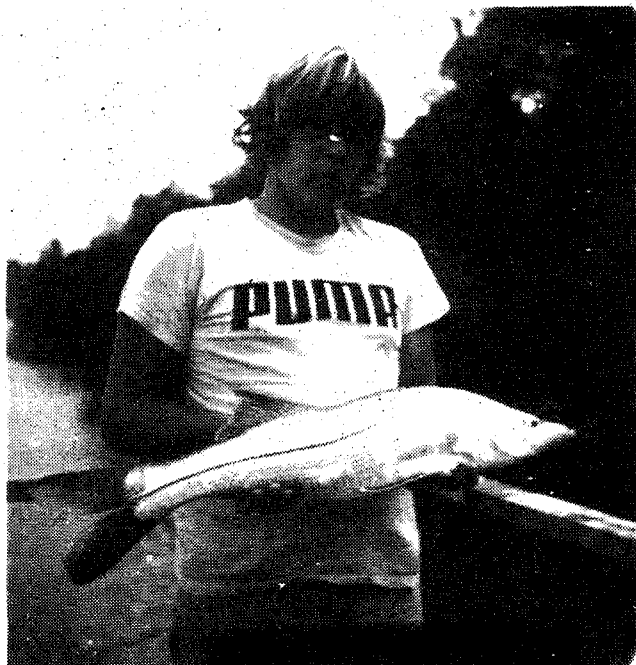
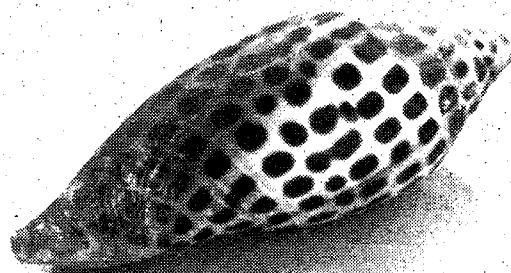

R.J. QUACKENBUSH, OF TAMPA, landed his first snook recently fishing with Capt. Mike Fuery. Quackenbush used a pinfish in Redfish Pass to get the seven pound fish to strike.

police report

There were three complaints of people shooting off fire works. Sanibel Police Department investigated, since the Fourth is long gone, and any celebrating should be well past by now. Naturally, the late celebrations were over by the time SPD arrived on the scene. Hopefully, the problem won't reoccur until next year. Time sure flies.....

In a world filled with infinitesimal problems....fighting, starvation, disease, political unrest....wouldn't you love a chance to sit the guy down who reported one hub cap gone and clue him in.

You know that feeling

you get when you close the door behind you and remember "just as it clicks shut" that you don't have your keys? Cheer up! You're not alone! There were several calls to SPD by people with the same problem!

Loved the report to SPD on a possible missing person. Possible. That allows for some question, but would like to give it a try. Let's see...."possibly missing" from about Thursday afternoon through Monday. Not bad....

Alligators Again. The Gator Aide people received more complaints about gators

chasing maids at one motel. At least their taste (pardon the pun) is improving. It used to be dogs.

Matter of fact...gators seem to be getting along better with canines too. One lady called SPD to report her dog in the water with a gator. She said the dog was "real tame" and was "anywhere with anyone. Poor old pup sure had lousy taste in friends!

NOW OPEN
COX'S
 FURNITURE
 1151 Business 41 - NEM
997-4184
 Quality - Used Furniture.
BUY-SELL-TRADE

Sanibel Taxi Cab Co. Inc. ON THE ISLAND:

HOURS 6 A.M. - 10 P.M. DAILY ALL CABS A/C
 MEET ALL FLIGHTS -- RESERVATIONS ONLY

472-2870

The Captiva Erosion Prevention District will hold workshop meetings every Tuesday at 4:00 p.m. at the Captiva Community Center, with the exception of the first Tuesday of each month. The regular monthly meeting will be on the first Tuesday of each month at 4:00 p.m. at the Captiva Community Center.

Daniel Burner, Jr.,
 Chairman

Sanibel Duplex Lots
 39,600 sq. ft.
\$35,000
 10% Down, Long Terms
472-4886

3 BEDROOM GULF FRONT CONDOMINIUM
 PONTE SANTO DE SANIBEL
 COMPLETELY FURNISHED
\$175,000
 E.A. BROWNE REALTY
 Reg. R.E. Broker
 472-5454

Pine Island
 5 Acre Tracts
\$35,000.
 10% Down, Long Terms
472-4886

AIR CONDITIONING YORK

- Commercial
- Residential
- Sales
- Commercial Refrigeration
- Electrical Contracting

ISLAND AIRE, INC.
 472-1260
 Sanibel

LEHIGH ACRES
 TWO BEDROOM ONE BATH ON LARGE 104 x 208 LOT
 LARGE FAMILY ROOM, DINING ROOM, WELL SPRINKLER SYSTEM, BEAUTIFULLY LANDSCAPED WITH CITRUS TREES Priced in the 30's.
E.D. Barbee & Son, Inc. REALTORS
 General Contractors
936-3478
 Sam Comparetto - Assoc.
 After Hours 936-1240

Priscilla Murphy Realty, Inc.

FIVE COTTAGE

plus delightful owners home. Walk to good Captiva beach. Extensive improvements completed in the last 2 years.
\$275,000

Stanley E. Johnson, Jr., G.R.I.
 President
 Sheila B. Snell, G.R.I.
 Vice President
 and associates

Main Office:
 P.O. Box 57
 Periwinkle Way,
 Sanibel Island,
 Florida 472-1511
Branch Office:
 Causeway Road,
 472-4121
Captiva Office:
 Andy Rosse Lane
 472-5154 472-1149
Rental Offices:
 Causeway Road
 472-4113

LAW OFFICES

ENGEL, ARONSON, FRIED & COHN

MAX P. ENGEL • MITCHELL D. ARONSON • HERBERT A. FRIED • DON S. COHN • JERALD J. CHLIPALA

UNCONTESTED DIVORCE \$150.00

WILLS (Simple) \$20.00

BANKRUPTCY (Personal - No Assets) \$200.00

Accidents (Automobile & Other) 25% of Recovery

Workmen's Compensation Claims 25% of Fee Recovered By State Statute
(Job Related Accidents)

REAL ESTATE CLOSINGS (Purchase or Sale) \$100 & up

Foreclosures (Real and Personal Property) \$100 & up

CORPORATIONS \$150.00

Commercial Litigation \$100 & up or monthly retainer
(representation of business and corporations)

ADOPTIONS (Uncontested) \$150.00

- Costs and Expenses not included in above fees
- All of above fees are subject to adjustment based upon special circumstances
- Consultations available on other criminal and civil matters

4388 Palm Beach Boulevard
FORT MYERS, Florida 33905
 Tel: 813/694-7111
 Monday through Friday 8:30-5:30,
 Saturday 9:00-1:00 (Evenings by Appointment)

1212 North 15th Street
 Corner of S.R. 29 and Lee Street
IMMOKALEE, Florida 33934
 Tel: 813/657-3616
 Monday through Friday 8:30-4:30
 (Evenings and weekends by appointment)

Classified Advertising

463-4421

472-5185

992-4544

Fort Myers Beach

Sanibel

Bonita Springs

NOTICE OF INTENTION TO REGISTER FICTITIOUS NAME

The undersigned does hereby certify that she conducting a Storage business at Fort Myers, Florida under the fictitious name of U-Storall of Fort Myers and that said firm is composed of the following persons whose names and places of residences are as follows:

JANETTE WILLS 5503 Estero Blvd. Fort Myers Beach, Florida 33931.

Ownership of U-Storall of Fort Myers is as follows:

JANETTE WILLS-100 percent ownership.

It is her intention to apply to the clerk of the Circuit Court in and for Lee County, Florida to register the said name of U-Storall of Fort Myers under the provisions of Section 865.09, Florida Statutes, 1963.

Witness my hand this, 27th day of June, 1978 Janette Wills.

Sworn to and subscribed to by JANETTE WILLS before me this 27th day of June, A.D. 1978.

Pamela Sue Luft
NOTARY PUBLIC

1 large dog kennel. \$25. 463-6879. TFN

Giff Shop, wall displays and gondolas, like new Call 472-2385 Evenings. 7-25

1975 snapper 30 inch riding mower with catcher, new engine. August 77, Best offer. 463-9632. 7-20

3 piece Bahama couch set-2 couches plus table. Olive Green solid with print cushions. Also color T.V. needs repair. 472-4783 after 6. TFN

DRUST M600 MODEL Photograph enlarger in fair condition. Made in Italy. \$25. Call 463-4423. TFN

G.E. 15 CU. FT. REFRIGARATOR. Gold-tone-3 yrs. old. FULL-SIZE BOX SPRINGS & MATTRESS. sleeps firm. Call 463-4421 from 9 to 5. Ask for Cindy or Mara. TFN

3/4 HORSEPOWER ELECTRIC WATER PUMP PRESSURE GAUGE AND SWITCH. CALL BETWEEN 8 and 5. 463-4421. TFN

Bicycles, tools, auto and truck tires, western saddle drafting board, clothing, etc. 8030 Estero Blvd. F.M.B. Saturday 7-29 to 2. 7-20

Wanted

WANTED TO BUY: Good Used Furniture or anything of Value. Call Mitch 992-4011 in Bonita Springs. TFN

Marine

DO YOU HAVE Fresh fish need grouper, snapper, or pompano filets. Call 992-0033. tfn

15 ft. Checkmate. 150 high performance mercury outboard, power trim. 3 props. \$22,000. 463-6879. TFN

SAILING ANYONE?

PAPA NUI Ft. Myers Beach Res. 332-1200 TFN

21 foot inboard speed boat. \$1450. 463-6879. TFN

27 Foot Watkins Sailboat. 6 months old. 3 Sails. 12 Horsepower. Yanmar Diesel. Loaded with extras. 463-2066. 7-20

Motorcycles For Sale

1959 Harley Davidson. 3 wheel trike custom seat 21 inch front wheel. 12 inch extension, \$1300. Call 992-0266. 7-27

Cars For Sale

1975-CJ 5 JEEP. Lt. Blue. 304 cubic in. 3 speed. 4 wheel-drive, power steering, brakes, Mag-wheels. Large tires. 14,000 plus miles. \$4,500. 473-2417. 463-2838. TFN

1966 FORD ECONOLINE VAN, 6 Cylinder 240. \$500.00. 463-6875, Morning or Evening. TFN

For Sale: 1965 Plymouth Fury, \$600. Call 463-2064 or 463-5261. TFN

1967 FORD GALAXIE \$200. 463-0208 or 472-4783 after 6.

1972 GMC HALF TON CUSTOM PICK-UP. V-8 automatic transmission, radio, heater. 50,600 miles, New paint, North Carolina Truck, no rust: \$1895. Call 542-6611 days. Ask for Bill Bostic. TFN

1969 Caprice, 9 passenger Station Wagon. Priced Right. Call 472-2901. TFN

1971 NOVA, 350 Headers, Holley Double Pumper, high left Cams, Mag-Wheels, New Tires, Black Top, White Bottom, Excellent Condition, no rust, no rot. \$1,800. 463-6537. TFN

71 - Chevelle Malibu 350. Very Clean. No reasonable offer refused. 482-1792. 7-20

1970 9 passenger station wagon. 363 engine. power brakes. power steering. air. radio. The Works. \$700. Call 992-3471 or 992-2217. TFN

Services

Boardman and Boardman - Complete Lawn Care, Mowing, Edging. References upon Request. 597-4026. TFN

ABSOLUTELY LOWEST PRICES IN TOWN FLORIDA ROOMS-ADAPTATIONS-ALTERATIONS-NEW HOMES. LICENSED-STATE CERTIFIED. ART-482-0986 ART 482-0986

BUSINESS AND MORTGAGE loans available. PHILLIP E. HAWLEY, MORTGAGE BROKER. 2170 Fowler St. Fort Myers, Florida 33901. 332-0493. TFN

ISLAND GLASS AND MIRROR Specializing in Custom Wall Mirrors. We Design to fit YOUR DECOR-glass table tops, custom mirrored furniture, screen doors, beveled mirrors, shower doors, patio door repairs, broken glass. 2244-D Periwinkle Way, Sanibel. Phone 472-5318. tfn

OUR TOLL FREE TELEPHONE NUMBER FOR ALL YOUR TRAVEL NEEDS CAN BE CALLED FROM ALL OUT OF STATE LOCATIONS. WRITE IT DOWN. IT'S 800-237-3104 - INTERVAL TRAVEL AGENCY - 1618 Periwinkle Way, Sanibel, Fla. LOCAL PHONE - 472-3171. tfn

SERVICES OFFERED: Dressmaking, alterations, custom fitting Designer of Custom Fashion Your idea or mine. Reasonable Prices. Call 463-4928. tfn

William S Sico Wood Floor sanding and refinishing Serving Southwest Florida. 992-0796. TFN

WAYNE'S LAWN CARE Mowing, Palm Trimming. Light Hauling. 463-9602 after 5. TFN

STORAGE UNLIMITED San Carlos and Kelly Rd., behind Captain's Car Wash. Many sizes included, dehumidified, 4x4x4. One month rental or longer. Full Security 481-6364. tfn

REPAIR AND REMODELING Licensed, bonded, and qualified workmanship. Call 463-9194. tfn

Help Wanted

Bookkeeping position part-time at Exon. 2 hrs. per day. Good pay. 463-5541. 7-20

WANTED - High School boys for summer yard work on Estero Island, full and Part-time. Call 463-6552. 9 A.M. to 5 P.M. 7-20

Maintenance Man needed for large motel. For Appointment. Call 463-6117. 7-20

Experienced Bus people. For appointment - 12 to 4 p.m. Island Pub Restaurant. 463-2033. F.M.B. tfn

WANTED - Part-time man for general yard work on Estero Island. Call 463-6552. 9 A.M. to 5 P.M. 7-20

Cleaning person-part-time mornings. Including weekends-possible full-time later. 463-0477 after 4 p.m. 7-20

WANTED - Full and Part-time cleaning ladies for cottages and efficiencies on Estero Island, willing to work occasional weekends. Call 463-6552. 9 A.M. to 5 P.M. 7-20

Maid needed, reliable, steady help for motel. 463-5778. TFN

Maids for large motel, wanted full-time. For appointment call 463-6117. 7-20

Bookkeeping position, part-time at Exon. 2 hours per day. Good Pay. 463-5541. 7-17

2 motel maids. Call 463-6132. F.M.B. 7-17

Now taking applications for dining room waitresses or bus persons. 463-4700, 1651 Estero Blvd., KENNY'S ON THE BEACH. F.M.B. Apply until 4PM daily. TFN

Help Wanted: Baby sitter wanted to care for 5 month old in my home. Full-time, good pay. 463-9591. TFN

Babysitter wanted for week-end mornings. 463-0477. 7-20

Permanent employment, women or men, to mow lawns and fairways: Bay Beach Golf Course. 463-2064. 7-27

Dispatchers, Sanibel Police Department. Must qualify under C.E.T.A. 472-3111. 7-27

Responsible party for light maintenance and cleaning, part-time evenings and weekends. 463-4473. 7-27

Real Estate Wanted

Would like to buy canal front lot. Please call. 463-0411. TFN

For Rent

Unfurnished Apartment 151 Eucalyptus. 2 bedroom. 2 bath. Yearly. 463-9356 or 463-4552. TFN

Sunset, Bayview on San Carlos. Brand new, 1 bedroom ground floor apartment, central heat and air conditioning carpet, privacy, unfurnished. Yearly Lease. TFN

NEW FURNISHED Gulf-front apartment - 2 bed., 2 bath, monthly or seasonal rate. 481-7793 days, 463-4922 eve. tfn

Furnished Private Room and Bath with house privileges. Call 992-4158. TFN

FOR RENT: Reserve now for next season beautiful new deluxe 2-bedroom, 1 1/2 bath gulf front apt. completely furnished and in excellent location. 463-6986. TFN

1 Rental Yearly. Extra Large, 1 bedroom apartment, close in, BLUE CHIP REALTY. F. M. B. TFN

2 Efficiencies for rent - \$15 per mo. Utilities furnished. 992-5470. tfn

FOR RENT: Small efficiency for rent on the beach. 463-9463. TFN

FOR RENT: Beach 1 and 2 bedroom, efficiency cottages - from \$55 weekly or \$155 monthly. Includes utilities. Mature Adults. NO PETS. 463-6554. TFN

Real Estate

CALL FOR CALL

Exchange counselor - You can exchange your unwanted property for something you really like. Deal with an experienced exchanger. Ralph A. Call, Realtor, P. O. Box 232, 1648 Periwinkle, Sanibel Island, Fla. 33957. 813-472-4127. tfn

New, unfurnished downstairs apartment. 2 bedroom, 2 bath, air, all electric. Large living room and dining area. Available June 15. \$300. mo. plus electric. 1st and last month plus security. No pets. 2 mature adults only. Across from gulf. Call 463-9695. TFN

Fort Myers Beach, 1 bedroom modern completely furnished apartment. Mature adults. Weekly or monthly. 463-2830. 8-10

3 bedroom Trailer. \$300 463-6041. tfn

Office or shop space for lease. 800 sq. ft. on Estero Blvd. in business center. BLUE CHIP REALTY, REALTORS. 463-5771. TFN

COMMERCIAL PROPERTY. 400 Sq. Ft. gulf view, prime beach location. 3 unique shops at same location. Call after 6. 463-9422. TFN

FOR RENT YEARLY LEASE - ISLAND REEF Condo. Renthouse, 2 bedroom, 2 Bath, no children or pets. Completely Furnished. \$725 Month plus Utilities. Call 912-377-2568. TFN

Island Beach Club 2 bedroom condo. Unfurnished. Never occupied. Includes drapes, carpeting and all appliances. \$400 mo. plus utilities. Call Jim Hermes at 472-4500 after 6:00 P.M. 7-25

PALMACRES For Sale or Rent - New 3-bedroom house on canal - Davit bases, landscaped, lanai with inside plantings. Just north of Sanibel causeway. \$89,500 or \$500 per month plus utilities. Minimum 6 months. 482-1219. tfn

BAYFRONT HOME. Furnished and equipped. 431 Estero Blvd. \$500. per month plus utilities and yard maintenance. Retired couple preferred. Yearly lease available or longer. See owner. Jerry Ursoleo or Jay Ursoleo for appointment. Call 463-6751. 463-6125. 463-6804. 463-4000. 463-9500. 463-6153 or call the Beach Bulletin. TFN

For Sale

MOBILE HOMES FOR SALE: A beautiful Ramada 2 bedroom, 2 bath enclosed Florida room, carport, etc. Replacement value \$22,500. Selling for \$18,900. Near Sanibel. Tropicana 481-2131. 7-25

FOR SALE - 2 bedroom, canal front condo at B-32 Tennis Place, Sanibel. Furnished \$49,500. Phone 472-5572, or 201-744-0304. tfn

Water front lot. 75 x 199. Seawalled. Call FRANK PORTER REALTY, INC. REALTORS. 463-4484. 7-20

3 bedroom. 2 1/2 bath. 2 car garage. Linda Loma Subdivision. \$49,500. 482-0924. TFN

BY OWNER - New beautiful 3 bedroom 2 bath custom built home, directly on back bay. 90 ft. seawalled lot, many extras. \$125,000. Call for appt. 463-6358. tfn

ISLAND REALES, INC. Registered Real Estate Broker sells Real Estate - 813-472-5173. tfn

HOW WOULD YOU LIKE the privacy of a preserve area in your backyard? Beautiful Matanzas Preserve borders the rear lot line of this lovely, three bedroom, 2 bath, Spanish style home. Built in L shape design, rooms look onto court yard with oak trees, shrubs and interesting bird life. \$58,500. Call SMITH REALTY 463-6753. Evenings 463-2447. TFN

BONITA SPRINGS. EXECUTIVE HOME. CBS Custom Built. Spanish, 3-bedroom-2-bath on large seawalled lot, beautifully landscaped. Many extras, \$110,000. See your realtor or call owner. 992-2721 or 992-2566. TFN

Sanibel Beachfront, 3 bedroom and 2 bath on 1/4 acre lot, 150 foot of white sand beach. BLUE CHIP REALTY, INC. REALTORS. 463-5771. TFN

Sanibel-Completely furnished 2-bedroom, 2-bath, Michigan home on Canal, Sundeck and Dock. Available May 13 to Dec. 1st. Cable T.V. Washer Dryer. A.C. 472-2267. TFN

IN BLUE RIDGE MOUNTAINS OF NORTH CAROLINA. 2 bedroom summer cabin with facilities and furnishings. On half Acre of forested land. 1 mile from town of Highlands. Low price. Directly from owner. Call 463-9743. TFN

A beautiful top quality 2 bedroom, 2 bath, tastefully furnished home. Finest Mobile community. Near Sanibel. Replacement Value, \$28,500. Selling for \$23,000. Tropicana 481-2131. 7-25

Bay Front Duplex, 83 Foot Seawall on Bay, 2 Bedroom, 2 Bath Each Side. Blue Chip Realty, Inc. 463-5771. TFN

Family investment, 2 duplexes, 4 units, excellent location, Ft. Myers. For sale by owner. Ph. 463-5206. TFN

MOBILE HOME, BAYSIDE ESTATES. 2 bedroom, 2 bath. Direct canal access. Central heat and air. Boat dock. Call FRANK PORTER REALTY, INC. REALTORS. 463-4484. 7-20

10 by 60, 1 bedroom, 1 bath, central-heat and air. Draperies, stove and refrigerator. Needs to be moved. \$2,500. 463-0363 till 5 P.M. TFN

For Sale - Two Mobile homes, one on water, Blue Chip Realty, Inc., Realtors. 463-5771. tfn

Mobile Home on Canal Dock, Room Addition, 2-Bedroom. 463-6537. TFN

For Sale - New 1 bdrm furnished mobile home on rental lot. Walk to beach. Beach Mobile Home Sales, 463-9357. tfn

Triplex. 2-1 bedroom, 1 bath units, plus 1-2 bedroom, 2 bath unit. On Estero Blvd. short walk to gulf. Call FRANK PORTER REALTY, INC. REALTORS. 463-4484. 7-20

DUPLEX LOT. In quiet neighborhood, area of new homes. Underground utilities, approximately 9,000 Sq. Ft. Cleared and Filled. Only \$21,000. Call SMITH REALTY 463-6753. Evenings 463-2447. TFN

Nice residential lot 75x130 on Estero Blvd. in Lagonna Shores subdv., \$18,950 by owners. 463-5206. TFN

CLASSIFIED INFORMATION

RATES Service Directory - \$1.75 an inch with each weekly insertion.

Classified Advertising - \$1 for the first ten words, five cents each extra word.

Boxed ads in classified section - \$1 extra.

Found Ads Those ads reporting found articles are free.

PHONES Fort Myers Beach, 463-4421 Bonita Springs, 992-4544

MAILING ADDRESS P.O. Box 2867, Fort Myers Beach, FL 33931.

Lost & Found

LOST Small Boston Bulldog. Black & White. Lost in vicinity of Matanzas Ct. Childs pet - children heart-broken. Please return. If you have any information contact the Mad Shopper. Or 463-6604 \$50 Reward. TFN

Lhasa Apso, Brown and White family pet. Name of dog is Fluffy. Call 472-2568 or 472-1765. 7-18

Miscellaneous

BUY SELL, TRADE. Stoves, refrigerator, furniture, most anything. Frank and Bob's Swap Shop. 2170 San Carlos Blvd. Open Tues.-Sat. 8 a.m. to 5.

Cute Kittens FREE to a good home. 8 weeks, shots and litter trained. 463-6111. TFN

Merchandise

For Sale

Ladies 26" bicycle for sale \$20. Call evenings 463-6459. 7-27

Flea Market, furniture household goods, books, toys, lots of clothing. Sat. 22nd, 8 to 1. 2101 Estero Blvd. F.M.B. 7-20

Garage sale, 1st street, Bonita Shores. Lots of goodies. week days. 10 to 4 992-2425. 7-20



OWN YOUR DREAM VACATION RESORT HOME for about the cost of a new car today!



FLORIDA



HAWAII



EUROPE

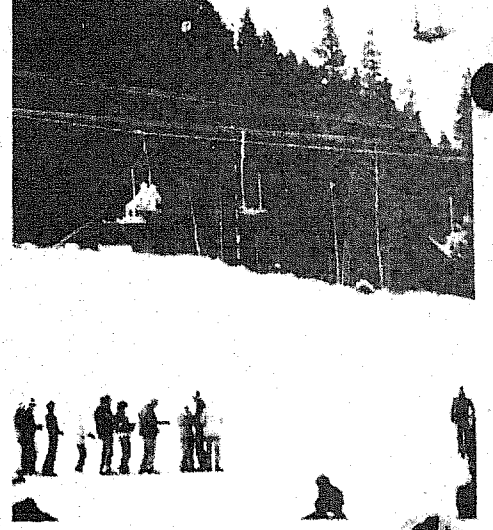

COLORADO



makes it possible!

Interval Ownership? A new form of real estate. A sensible vacation plan that makes it possible for you to purchase a luxuriously furnished vacation condominium for the weeks you want it. You receive a warranty deed for this time. It's so completely furnished that all you need to bring is a toothbrush and a few clothes.

Interval ownership is the simple and logical answer to the vacation home dilemma. It offers the family of even modest means a guarantee that they will have a luxury vacation home at an affordable cost. Forget the risk of arriving at your favorite beach resort without reservations. Forget costly motels that offer only bedroom and bath facilities. Forget the worry of renting out a condominium that you own year-round and use only a few weeks each year.

Looking down the road, with today's inflationary trend, will you be able to afford a luxury vacation at today's prices five or ten years from now?

With interval ownership you can. For as little as \$5,000, you can own a luxury condominium week to use and enjoy. You can will it to your children, sell or rent it any time at market value. It's your real estate.

Reasons to buy interval ownership right now? Prices may never be lower. Vacation costs are soaring. The average family of four will spend more than \$1,500 on their vacation this year and costs are rising. The bulk of these costs are for accommodations and food. Accommodations frequently are not as advertised and sometimes even with guaranteed reservations, are not available when you arrive. Eating out all the time is not only tiresome but extremely expensive.

An interval ownership bonus! A special plus for vacationers who have the wanderlust. Through an exchange program available to you, it is possible to trade your vacation weeks with other interval ownership resorts in Mexico, Hawaii, Europe, Colorado and many other luxury resorts in the United States.

The practicality of interval ownership is obvious and stunning in its simplicity. It allows you to purchase the resort condominium for the exact number of weeks you will use it. The purchase price is a one-time real estate expenditure.

With interval ownership you not only bring back pleasant vacation memories but you own the vacation property. It's real estate!

Just figure what you paid for your vacation last year and add on the rising costs over the next five years. Then, compare those costs with interval ownership over the next five years. Think of it. Your luxury vacation home can pay for itself in a few years!

Now is the time to act. CAPTRAN, INC., the interval ownership company on Sanibel Island, is presently offering for purchase luxury condominiums in three resorts on Sanibel Island, Fort Myers Beach and Treasure Island, Florida. All have inspiring views of the Gulf. Costs vary according to the type of accommodations, location and time period you choose.

It is not too good to be true. There are no gimmicks, no hidden costs, and no surprises. You actually own the week or weeks of the year in the resort of your choice. There are a number of floor plans from which to choose. Outside of the initial purchase price, which can be financed just like your automobile, you pay a small annual maintenance fee and a per diem charge for water and electricity only for the days you are using your condominium.

You get all the amenities your family wants without the hassle.

Act today! Get that dream vacation condominium now at an affordable price. Interval ownership is the way to assure yourself of a luxurious vacation. It's real estate. Interval ownership is for the family with 20-20 vacation foresight.

Your permanent dream vacation condominium in a luxury resort with the opportunity to trade weeks with other interval owner resorts around the world, has to be a bargain at these prices.

Clip and mail the coupon below - or bring it to Sanibel for the fun of it! Some family will win a Free week stay at a Captran resort. Simply mail the coupon below, indicating which resort area you'd like information on - or bring it to our reception center at Lighthouse Resort & Club on the east end of Sanibel. Or call 472-5181. Models open 9 a.m. to 9 p.m. every day of the week.

WIN A WEEK'S VACATION AT YOUR CHOICE OF CAPTRAN'S LUXURY RESORTS!

Drawing to be held September 15th. Coupon must be postmarked no later than September 10th. One coupon per family.

Please send me more information. I am interested in _____ weeks during the month(s) of _____

I prefer a () one bedroom unit. () two bedroom unit. () efficiency unit.
Location preferred () Ft. Myers Beach () Sanibel () St. Pete Beach

NAME _____

ADDRESS _____

CITY _____ STATE _____ ZIP _____

Captran Inc. 1517 Periwinkle Way • Sanibel, Florida 33957

(CLIP AND MAIL THIS COUPON)

JOIN US FOR AN INFORMATIVE BREAKFAST SATURDAY OR WEDNESDAY MORN... 472-5181

Enjoy a full breakfast on us and see a short but informative film on this exciting Interval Ownership way to better vacations for less. There's no obligation, of course, for this 9 a.m. eye opener to be held at TOP OF THE MAST (Sanibel). Reservations are required, however, so we know how many eggs and trimmings to fix. CALL BRIDGIT at 472-5181 Today.